

REVISION HISTORY						
ISSUE	DCN	DESCRIPTION	DATE	DRAWN	CHECK	APPROVED
4	3078	MOTOR CHANGED FROM Z-EMDC2CBCEC TO Z-EMDC2ABCEC.	22/01/13	GS	SJ	GS
5	3938	PUMP CHANGED FROM Z-PMPGEC11WD TO Z-PMPGECWD12WDH.	13/08/19	DM		

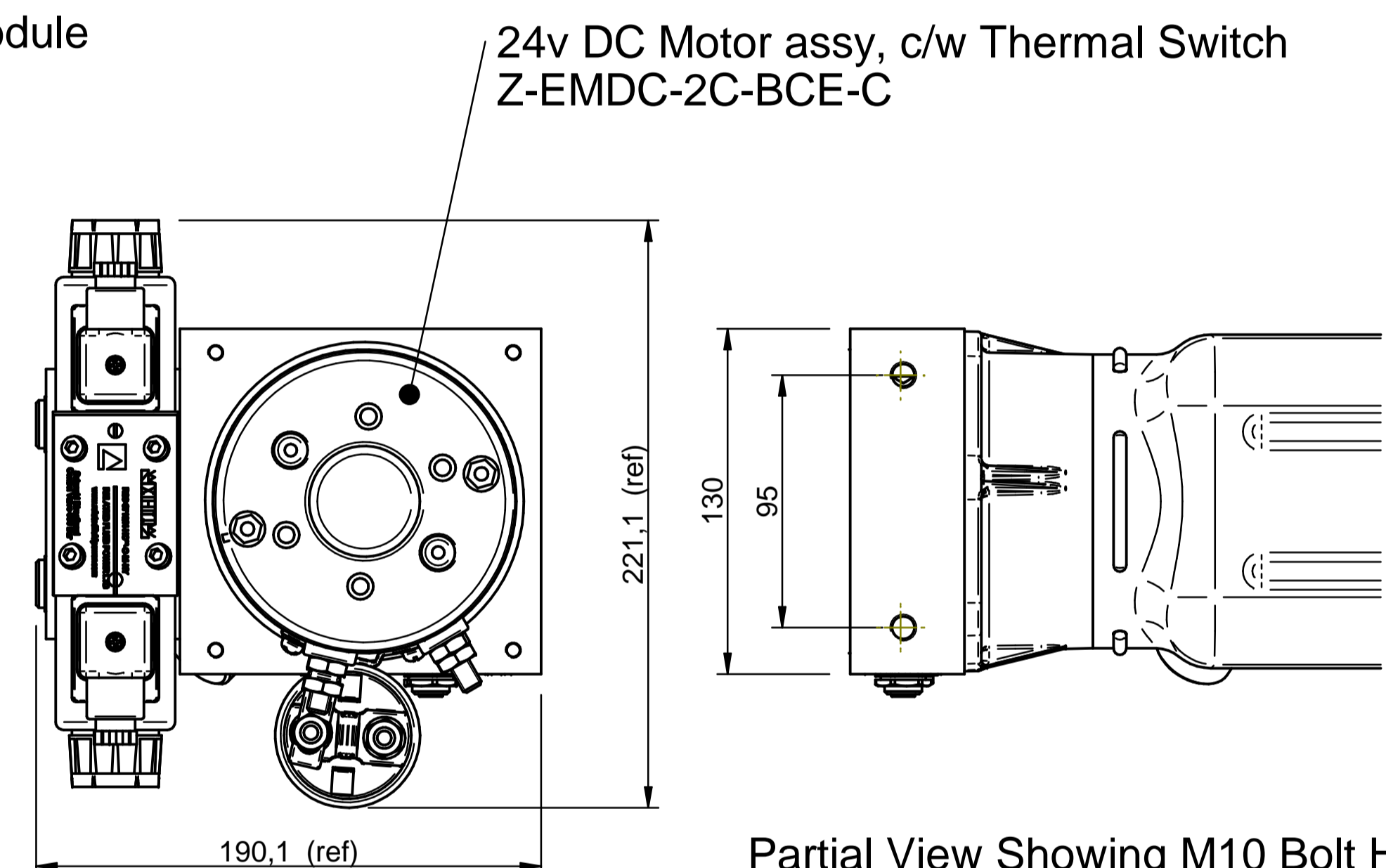

Partial View Showing M10 Bolt Holes

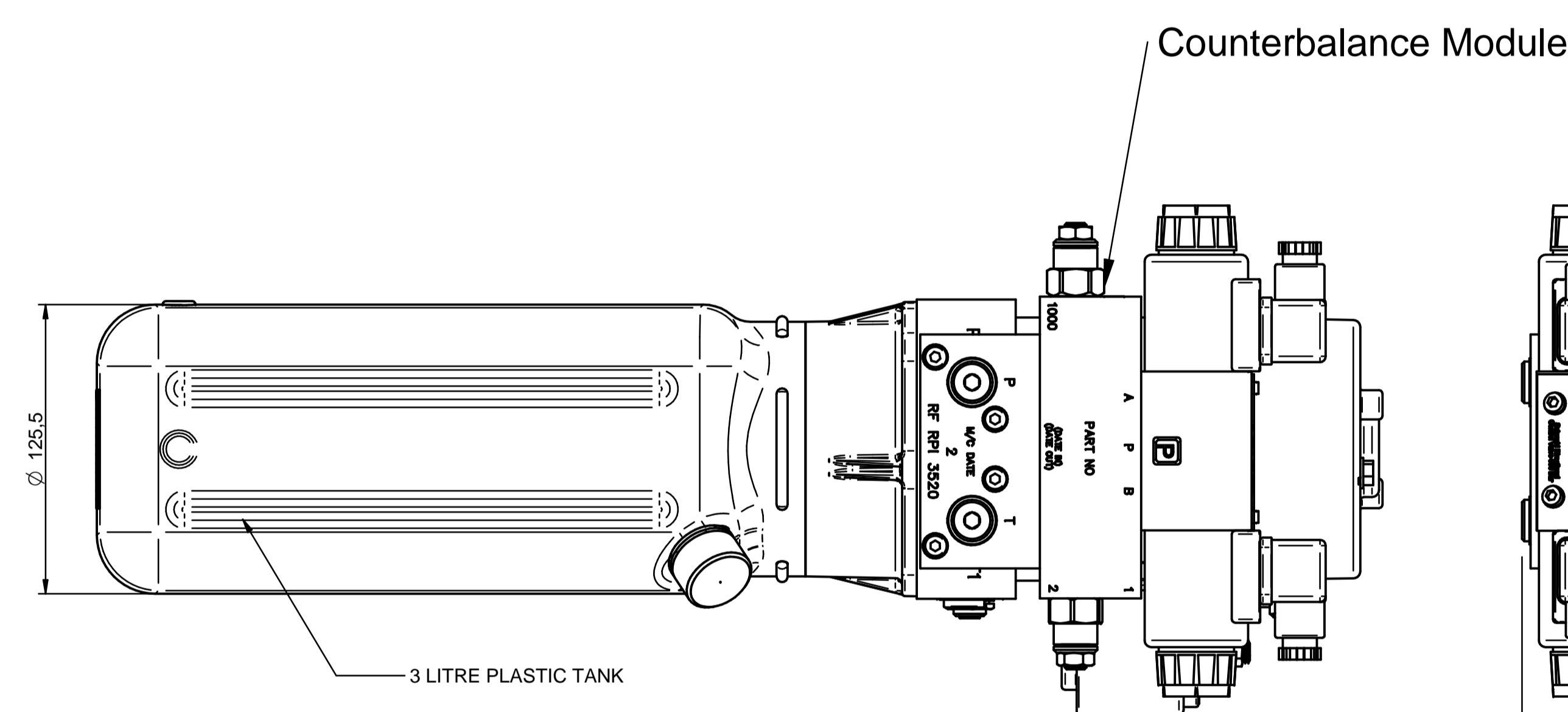
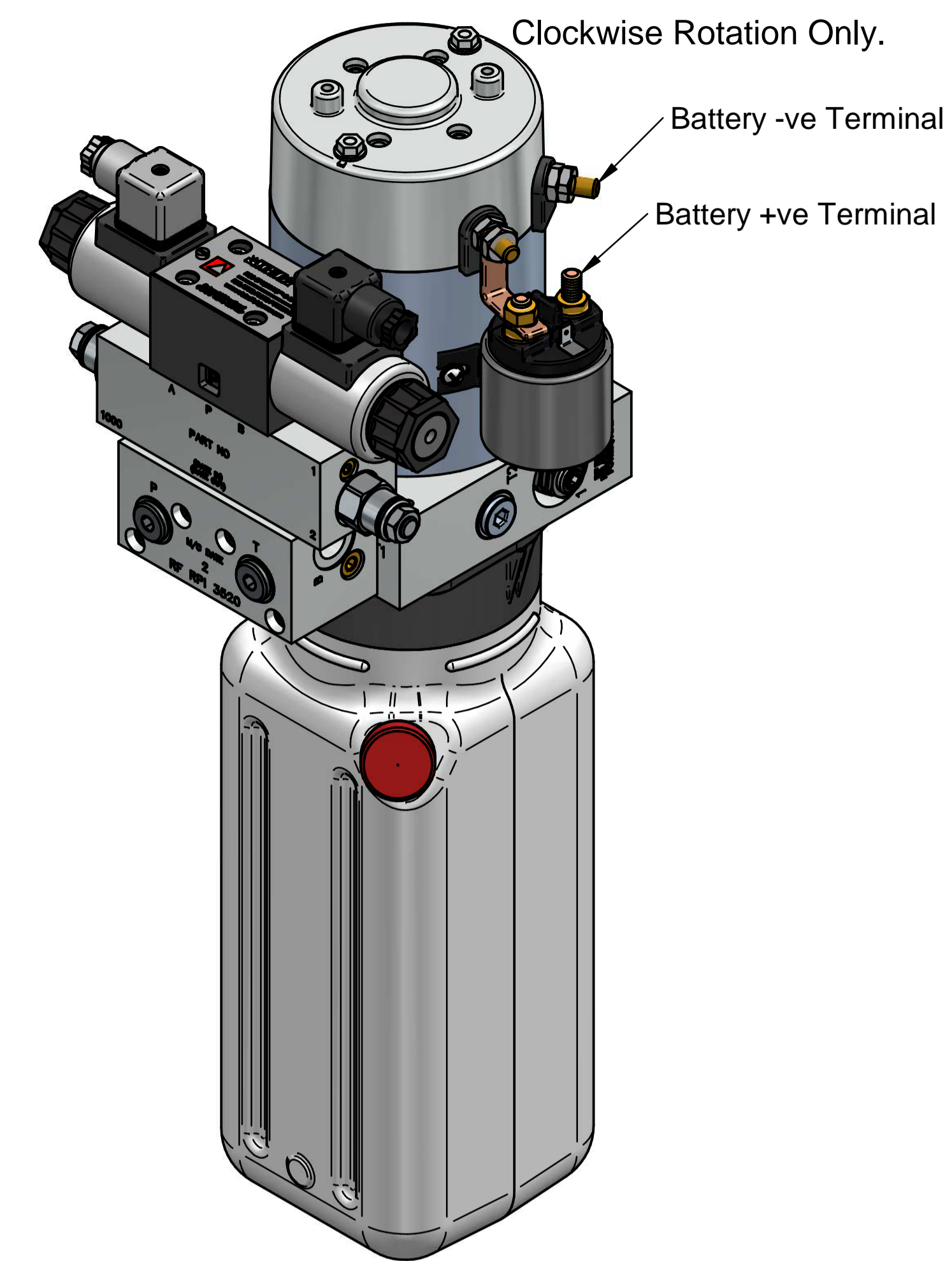
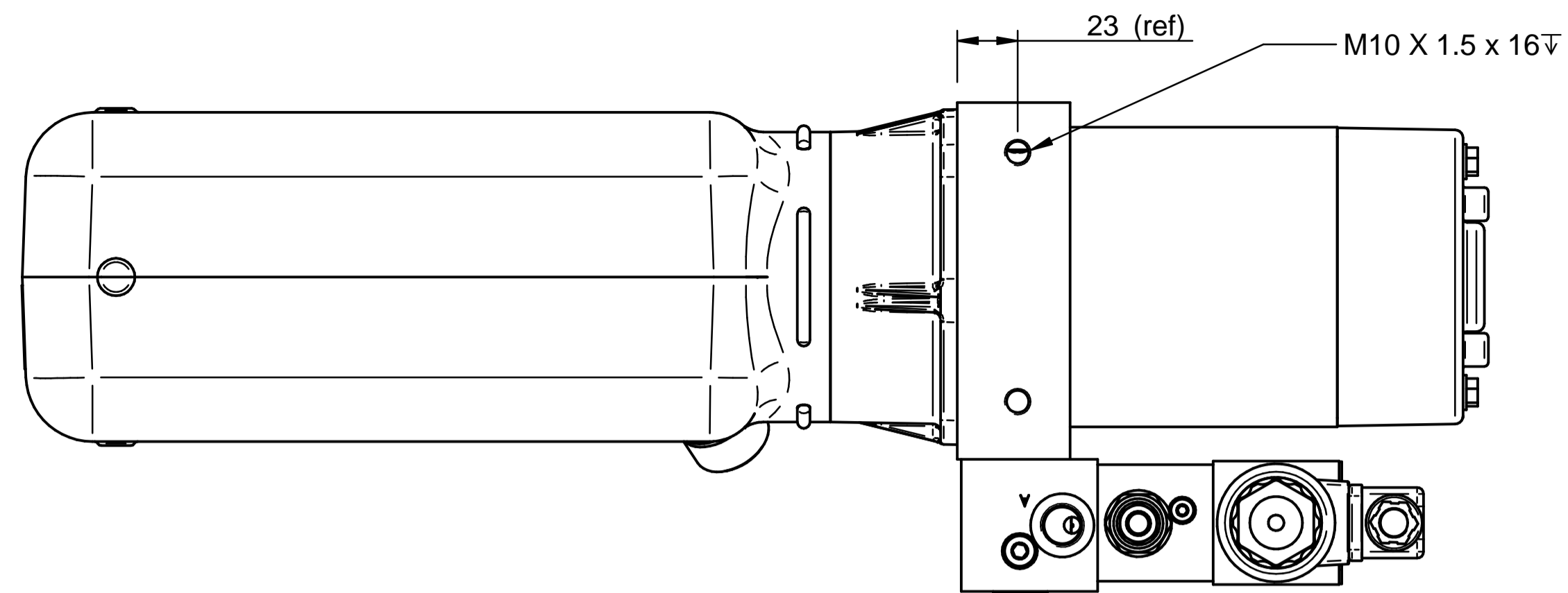
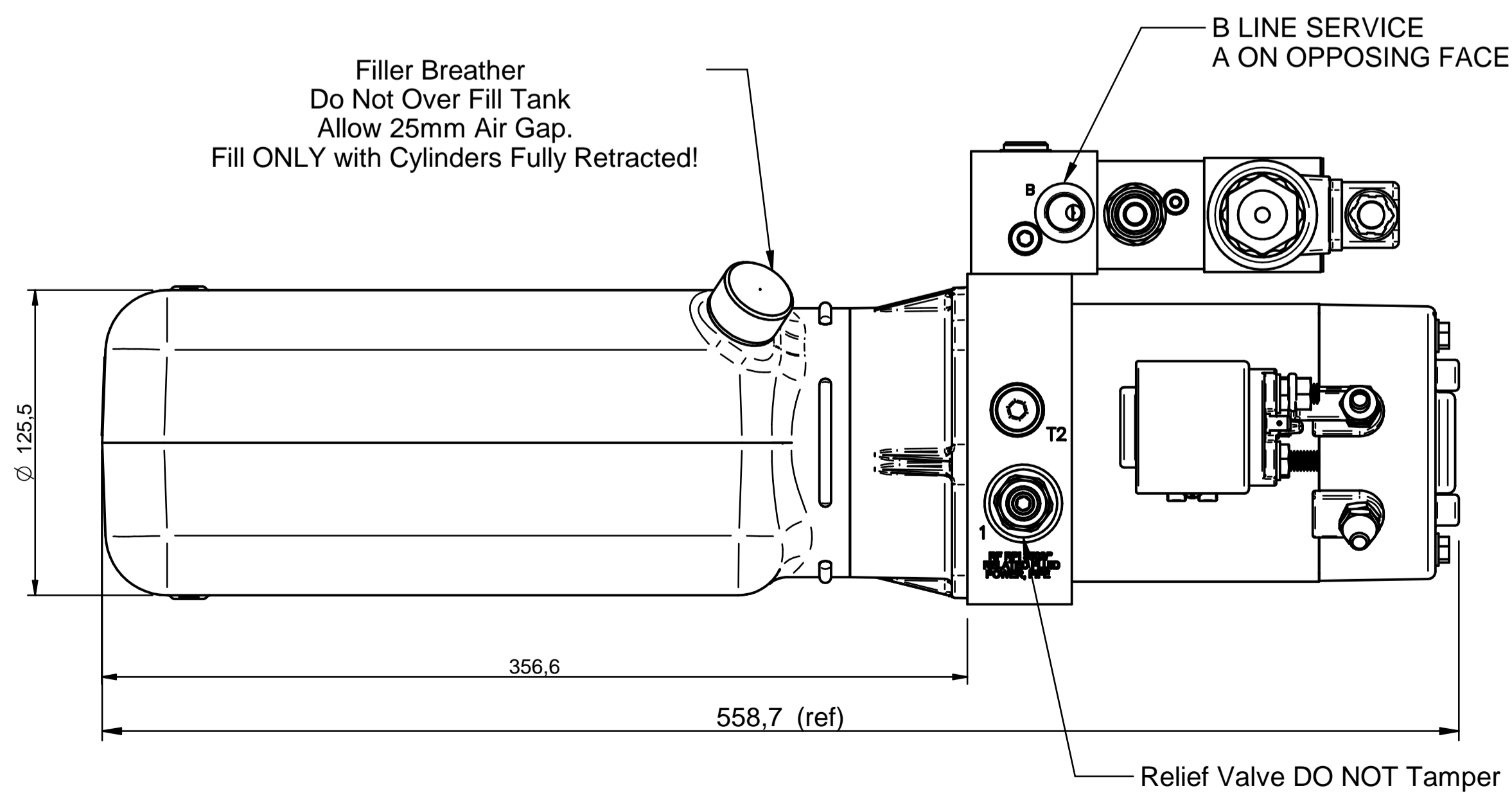
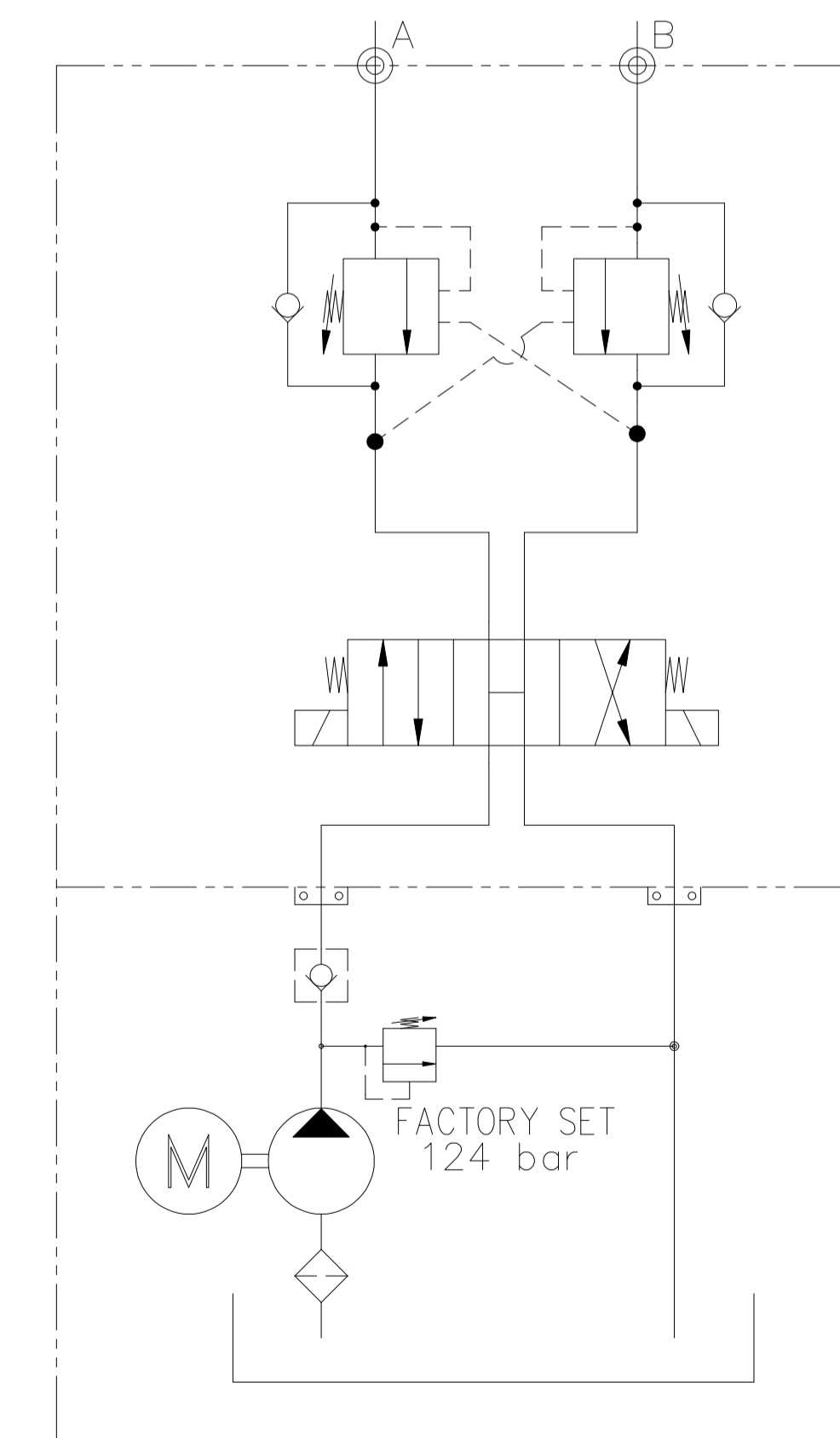

Power unit specification	
Motor	24v DC 2.2kW
Pump	1.2 cc/rev
Pressure	124 bar
Flow	4 Lpm @ 100 bar
Tank	2.5 Ltr Usable Vertical

APPROVED	AS	DATE		TITLE	24Vdc Power Unit Vertical Cetop3 Open Centre Valve with Cetop3 Double Overcentre Valve Module	SCALE	1 : 2	A1	
CHECKED	GS	DATE		CUSTOMER PART No.		THIRD ANGLE PROJECTION			
DRAWN	CA	DATE	15/12/08	PART No.	ZAV-GFD0001				
www.relatedfluidpower.com Tel: (01334) 655600 Fax: (01334) 650006				This drawing is the property of RELATED FLUID POWER Ltd. and is confidential. It must not be reproduced or shown to third parties without permission.		SHEET OF	1	ISSUE	5

