

Z8 Z45/22 DC

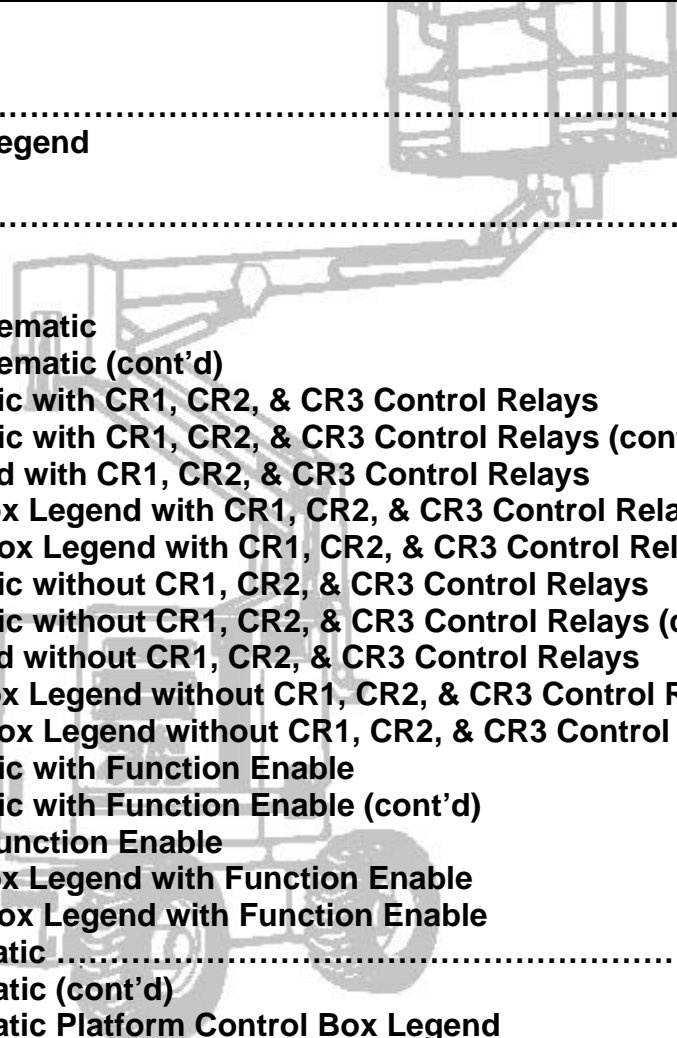

Page:	Model:	Serial Number:
Z8-01	Z45/22 DC – Electrical Schematic	4587-1101 to 4588-1549
Z8-02	Z45/22 DC – Electrical Schematic Legend	" " " "
Z8-03	Z45/22 DC – Wiring Diagram	" " " "
Z8-04	Z45/22 DC – Electrical Schematic	4588-1550 & above
Z8-05	Z45/22 DC – Electrical Schematic	" " " "
Z8-06	Z45/22 DC – Wiring Diagram	" " " "
Z8-07	Z45/22 DC Kilovtov – Electrical Schematic	
Z8-08	Z45/22 DC Kilovtov – Electrical Schematic (cont'd)	
Z8-09A	Z45/22 MP DC – Electrical Schematic with CR1, CR2, & CR3 Control Relays	
Z8-09B	Z45/22 MP DC – Electrical Schematic with CR1, CR2, & CR3 Control Relays (cont'd)	
Z8-10	Z45/22 MP DC – Relay Panel Legend with CR1, CR2, & CR3 Control Relays	
Z8-11	Z45/22 MP DC – Ground Control Box Legend with CR1, CR2, & CR3 Control Relays	
Z8-12	Z45/22 MP DC – Platform Control Box Legend with CR1, CR2, & CR3 Control Relays	
Z8-13A	Z45/22 MP DC – Electrical Schematic without CR1, CR2, & CR3 Control Relays	
Z8-13B	Z45/22 MP DC – Electrical Schematic without CR1, CR2, & CR3 Control Relays (cont'd)	
Z8-14	Z45/22 MP DC – Relay Panel Legend without CR1, CR2, & CR3 Control Relays	
Z8-15	Z45/22 MP DC – Ground Control Box Legend without CR1, CR2, & CR3 Control Relays	
Z8-16	Z45/22 MP DC – Platform Control Box Legend without CR1, CR2, & CR3 Control Relays	
Z8-17A	Z45/22 MP DC – Electrical Schematic with Function Enable	
Z8-17B	Z45/22 MP DC – Electrical Schematic with Function Enable (cont'd)	
Z8-18	Z45/22 MP DC – Relay Panel with Function Enable	
Z8-19	Z45/22 MP DC – Ground Control Box Legend with Function Enable	
Z8-20	Z45/22 MP DC – Platform Control Box Legend with Function Enable	
Z8-21A	Z45/22 DC 2WD – Electrical Schematic	Z45-4916 & above
Z8-21B	Z45/22 DC 2WD – Electrical Schematic (cont'd)	" " " "
Z8-22	Z45/22 DC 2WD – Electrical Schematic Platform Control Box Legend	" " " "

Z8 Z45/22 DC (cont'd)

Page:	Model:	Serial Number:
Z8-23	Z45/22 DC – Electrical Schematic Lift/Drive Select with LVI/BCI Option	
Z8-24	Z45/22 DC 2WD – Electrical Schematic Ground Control Box Legend	Z45-4916 & above
Z8-25	Z45/22 DC – Manifold Electrical Connections	
Z8-26	Z45/22 DC – Chassis Electrical Connections	
Z8-27	Z45/22 DC – Hydraulic Schematic	4588-1550 & above
Z8-28	Z45/22 DC – Drive Function Hydraulic Schematic with Sundstrand Piston Wheel Motor	" " " "
Z8-29	Z45/22 DC – Lift Function Manifold Drawing/Legend	" " " "
Z8-30	Z45/22 DC – Drive Function Manifold	" " " "
Z8-31	Z45/22 MP DC – Hydraulic Schematic	
Z8-32	Z45/22 MP DC – Hydraulic Schematic Legend	
Z8-33	Z45/22 DC 2WD – Hydraulic Schematic	Z45-4916 & above

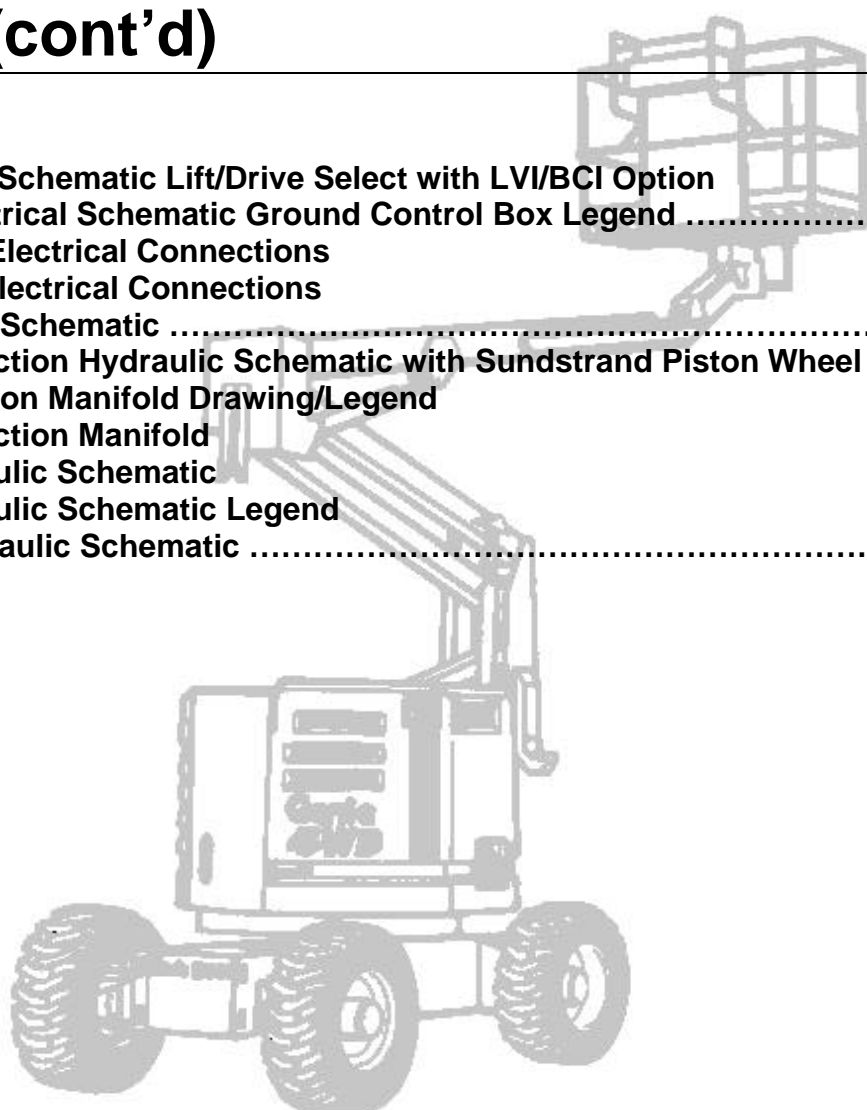

Z45/22 DC
ELECTRICAL SCHEMATIC
SERIAL# 4587-1101 TO 4588-1549

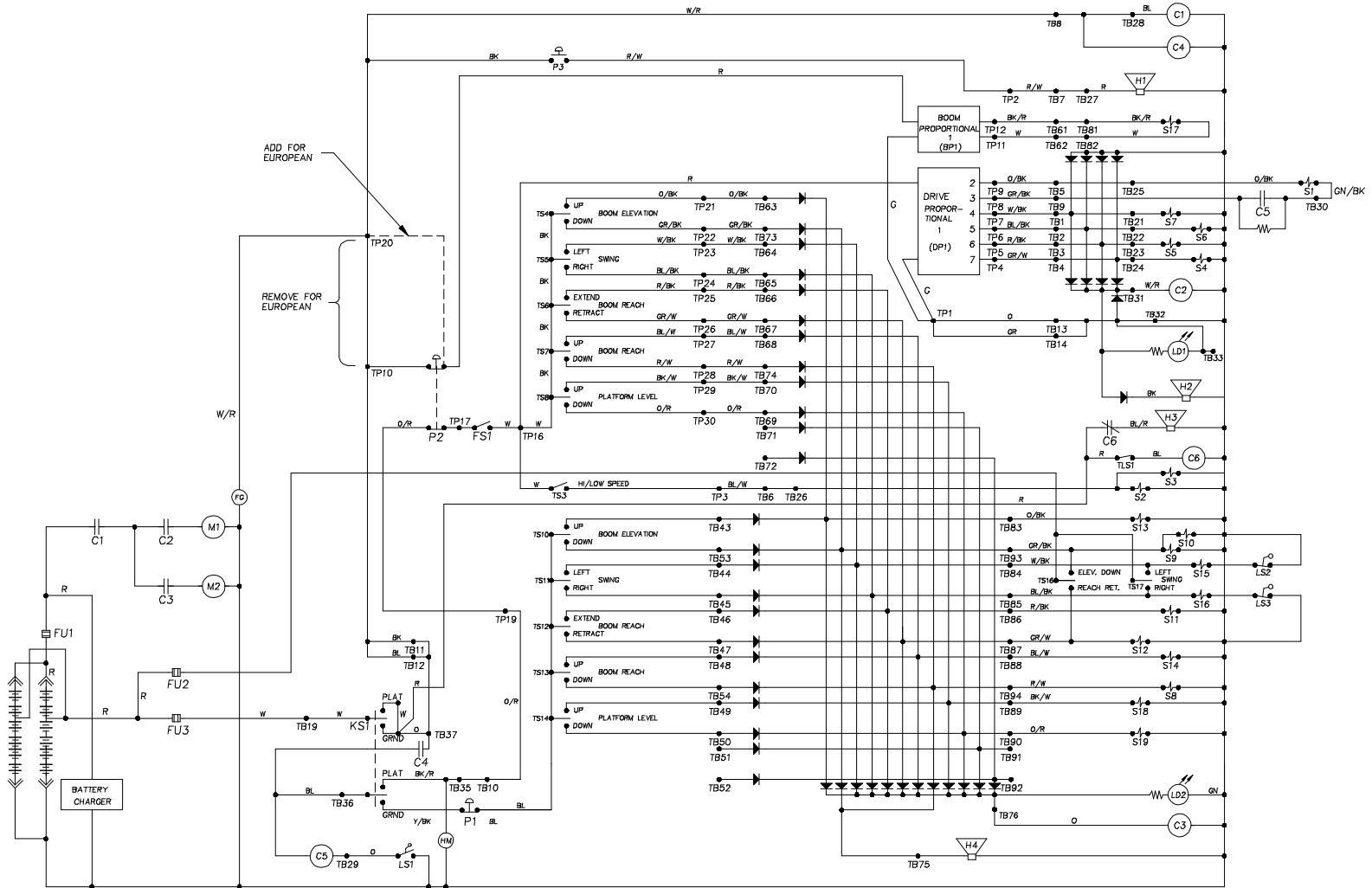

Z45/22 DC
ELECTRICAL SCHEMATIC LEGEND
SERIAL# 4587-1101 TO 4588-1549

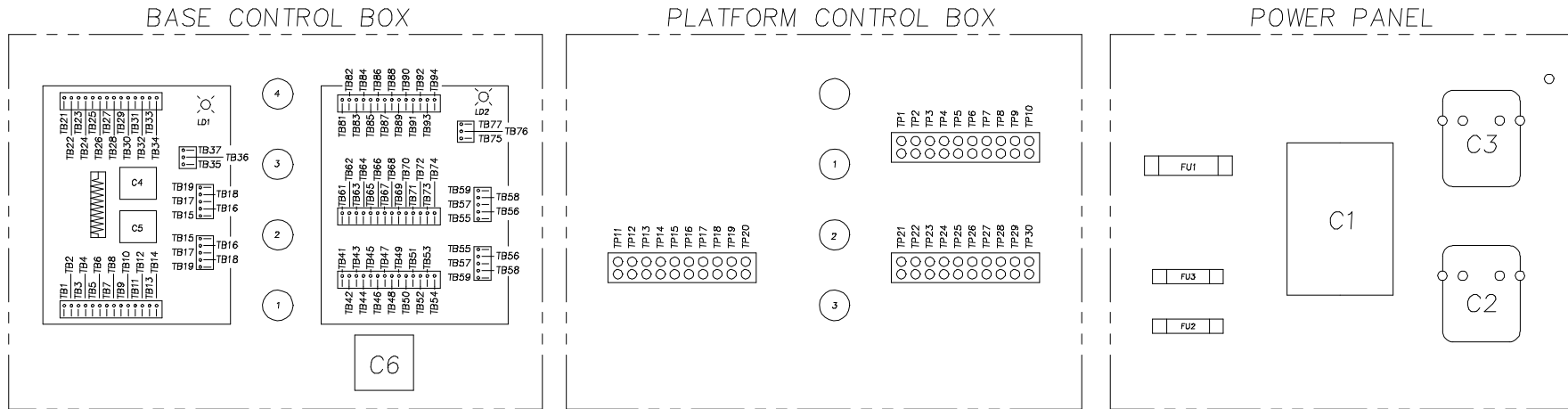

BP1	PROPORTIONAL CTL	OEM BOOM CONTROL	PLATFORM	S8	SOLENOID	BOOM REACH DOWN	CHASSIS
C1	36V RELAY	MOTOR/PUMP MASTER	CHASSIS	S9	SOLENOID	BOOM ELEVATE DOWN	CHASSIS
C2	36V RELAY	DRIVE MOTOR START	CHASSIS	S10	SOLENOID	BOOM ELEVATE DOWN	CHASSIS
C3	36V RELAY	BOOM MOTOR START	CHASSIS	S11	SOLENOID	BOOM REACH EXTEND	CHASSIS
C4	24V RELAY	CONTROL ACTIVATE	CHASSIS	S12	SOLENOID	BOOM REACH RETRACT	CHASSIS
C5	24V RELAY	HIGH/LOW SPEED SELECTION	CHASSIS	S13	SOLENOID	BOOM ELEVATE UP	CHASSIS
C6	24V RELAY	TILT LEVEL RELAY (NC)	CHASSIS	S14	SOLENOID	BOOM REACH UP	CHASSIS
DP1	PROPORTIONAL CTL	OEM DRIVE & STEERING CONTROL	PLATFORM	S15	SOLENOID	BOOM SWING LEFT	CHASSIS
FG	GAGE	BATTERY CHARGE INDICATOR	PLATFORM	S16	SOLENOID	BOOM SWING RIGHT	CHASSIS
FS1	FOOT SWITCH	POWER ON/OFF	PLATFORM	S17	SOLENOID	BOOM PROPORTIONAL SOLENOID	CHASSIS
FU1	300 AMP FUSE	MASTER FUSE	CHASSIS	S18	SOLENOID	PLATFORM LEVEL UP	CHASSIS
FU2	10 AMP FUSE	AUXILIARY BOOM CIRCUIT	CHASSIS	S19	SOLENOID	PLATFORM LEVEL DOWN	CHASSIS
FU3	10 AMP FUSE	CONTROL CIRCUIT	CHASSIS	TP1-TB14	TERMINALS	INPUT TERMINALS P/N 45051	CHASSIS
H1	HORN	SERVICE HORN	CHASSIS	TP15-TB19	TERMINALS	INPUT TERMINALS P/N 45051	CHASSIS
H2	HORN	TRAVEL ALARM (OPTIONAL)	CHASSIS	TP35-TB37	TERMINALS	OUTPUT TERMINALS P/N 45051	CHASSIS
H3	HORN	TILT LEVEL INDICATOR	CHASSIS	TP41-TB54	TERMINALS	INPUT TERMINALS P/N 45050	CHASSIS
H4	HORN	DESCENT HORN (OPTIONAL)	CHASSIS	TP55-TB59	TERMINALS	INPUT TERMINALS P/N 45050	CHASSIS
HM	HOUR METER	RUNNING HOURS	CHASSIS	TP61-TB74	TERMINALS	INPUT TERMINALS P/N 45050	CHASSIS
KS1	KEY SWITCH	CHOOSE CONTROL LOCATION	CHASSIS	TP75-TB77	TERMINALS	OUTPUT TERMINALS P/N 45051	CHASSIS
LD1	LED	DRIVE FUNCTIONS	CHASSIS	TP81-TB94	TERMINALS	OUTPUT TERMINALS P/N 45050	CHASSIS
LD2	LED	BOOM FUNCTIONS	CHASSIS	TP21-TP34	TERMINALS	OUTPUT TERMINALS-PLATFORM CONTROL	PLATFORM
LS1	LIMIT SWITCH	BOOM ELEV. VS. SPEED (SHOWN W/BOOM UP)	BOOM	TP1-TP14	TERMINALS	INPUT/OUTPUT TERMINALS-PLATFORM	PLATFORM
LS2	LIMIT SWITCH	SWING STOP	CHASSIS	TL51	LEVEL SWITCH	3.5 DEG. TILT LEVEL INDICATOR (NC)	CHASSIS
LS3	LIMIT SWITCH	SWING STOP	CHASSIS	TS3	TOGGLE SWITCH	HIGH/LOW SPEED SELECTION	PLATFORM
M1	MOTOR	DRIVE PUMP	CHASSIS	TS4	TOGGLE SWITCH	BOOM ELEV. UP/DOWN	PLATFORM
M2	MOTOR	BOOM PUMP	CHASSIS	TS5	TOGGLE SWITCH	BOOM SWING LEFT/RIGHT	PLATFORM
P1	PALM SWITCH	POWER ON/OFF	CHASSIS	TS6	TOGGLE SWITCH	BOOM REACH EXTEND/RETRACT	PLATFORM
P2	PALM SWITCH	POWER ON/OFF	PLATFORM	TS7	TOGGLE SWITCH	BOOM REACH UP/DOWN	PLATFORM
P3	PALM SWITCH	HORN	PLATFORM	TS8	TOGGLE SWITCH	PLATFORM LEVEL UP/DOWN	PLATFORM
S1	SOLENOID	DRIVE PROPORTIONAL SOLENOID	CHASSIS	TS10	TOGGLE SWITCH	BOOM ELEV. UP/DOWN	CHASSIS
S2	SOLENOID	DRIVE SERIES MODE	CHASSIS	TS11	TOGGLE SWITCH	BOOM SWING LEFT/RIGHT	CHASSIS
S3	SOLENOID	DRIVE SERIES MODE	CHASSIS	TS12	TOGGLE SWITCH	BOOM REACH EXTEND/RETRACT	CHASSIS
S4	SOLENOID	STEER RIGHT	CHASSIS	TS13	TOGGLE SWITCH	BOOM REACH UP/DOWN	CHASSIS
S5	SOLENOID	STEER LEFT	CHASSIS	TS14	TOGGLE SWITCH	PLATFORM LEVEL UP/DOWN	CHASSIS
S6	SOLENOID	TRAVEL REVERSE	CHASSIS	TS16	TOGGLE SWITCH	AUX. CONTROLS ELEV. DOWN/REACH RETRACT	CHASSIS
S7	SOLENOID	TRAVEL FORWARD	CHASSIS	TS17	TOGGLE SWITCH	AUX. CONTROLS SWING LEFT/RIGHT	CHASSIS

Z45/22 DC
 WIRING DIAGRAM
 SERIAL# 4587-1101 TO 4588-1549

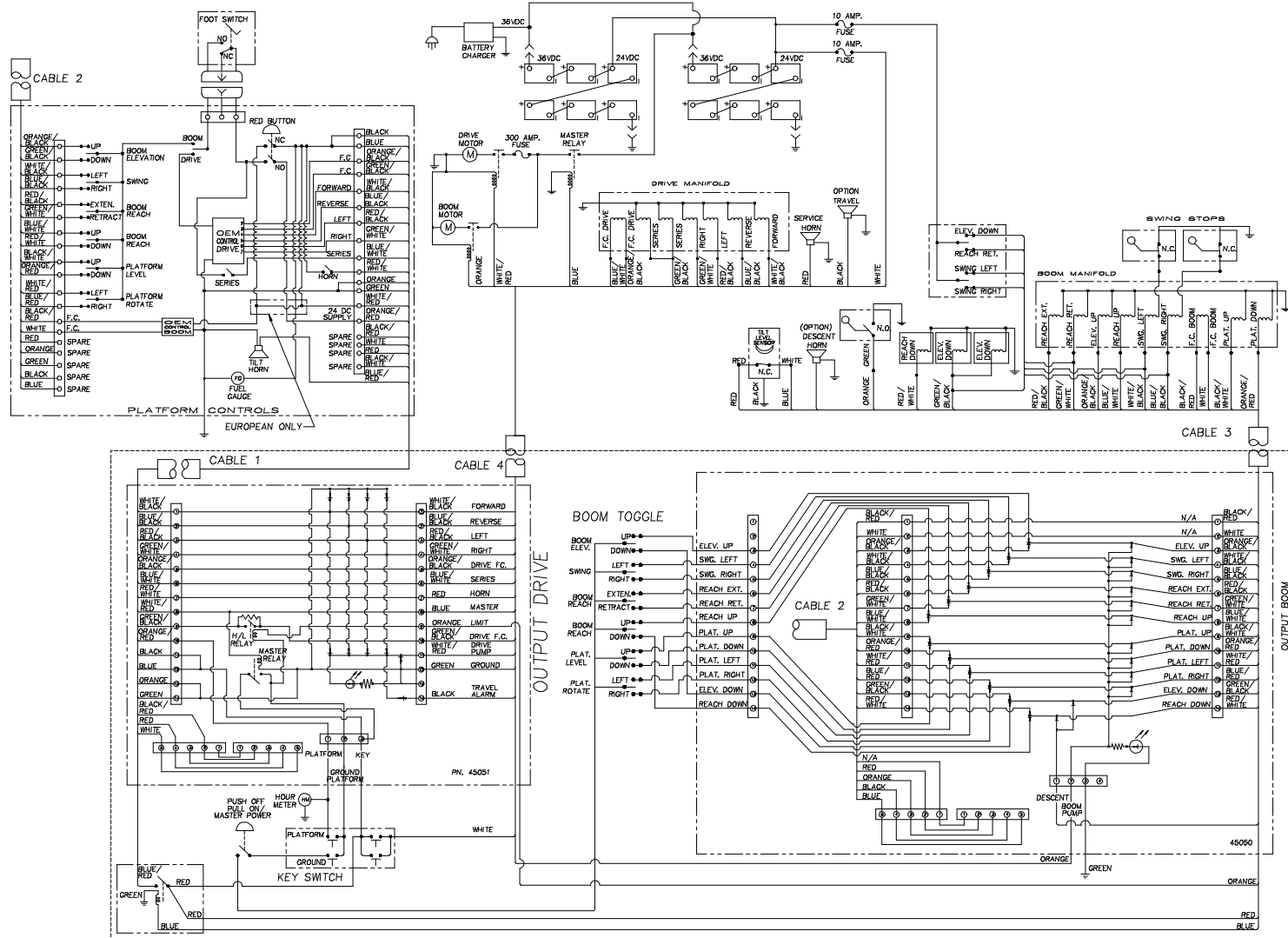

Z45/22 DC
ELECTRICAL SCHEMATIC
SERIAL # 4588-1550 & ABOVE

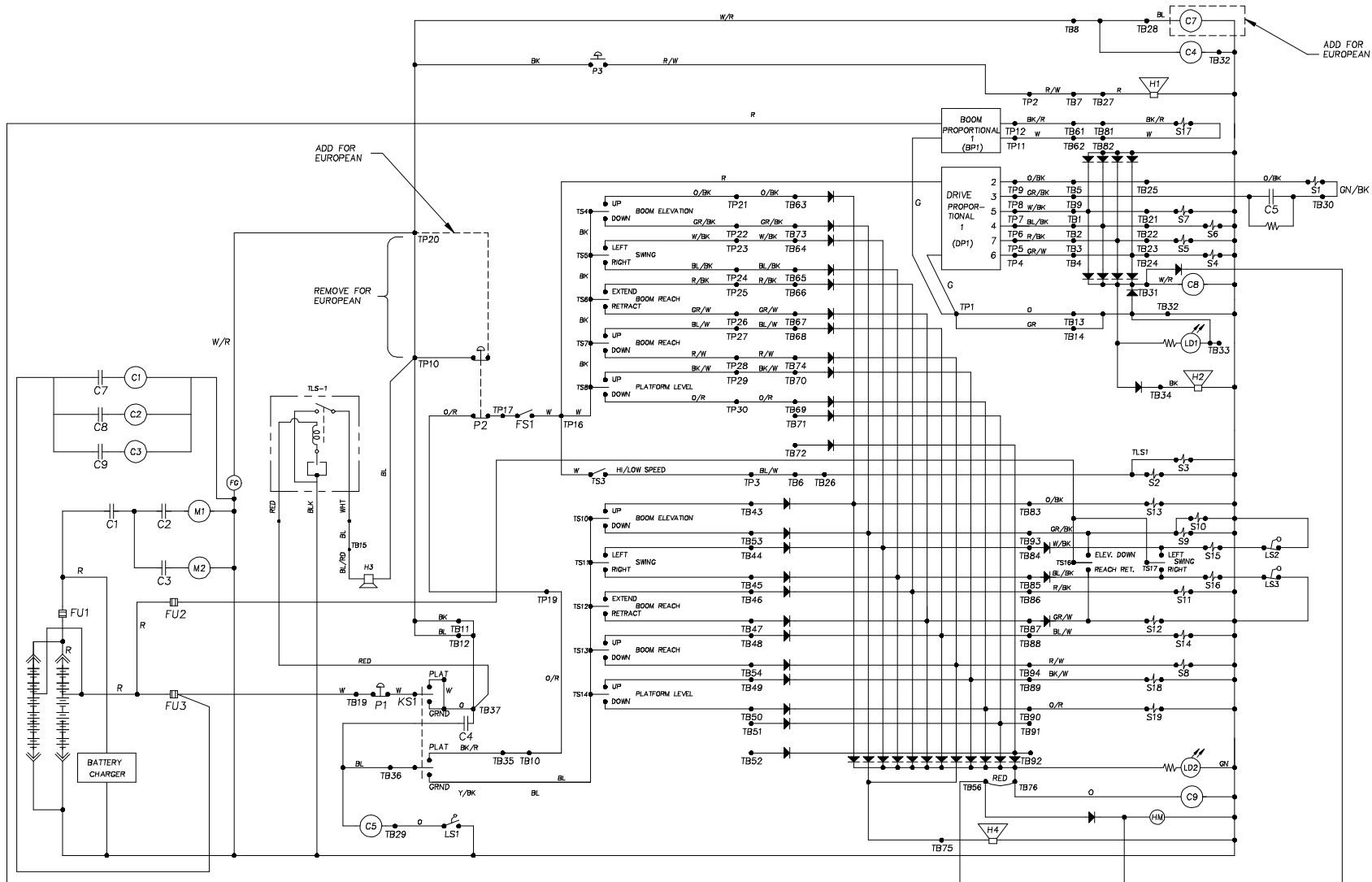

Z45/22 DC
ELECTRICAL SCHEMATIC
SERIAL #4588-1550 & ABOVE

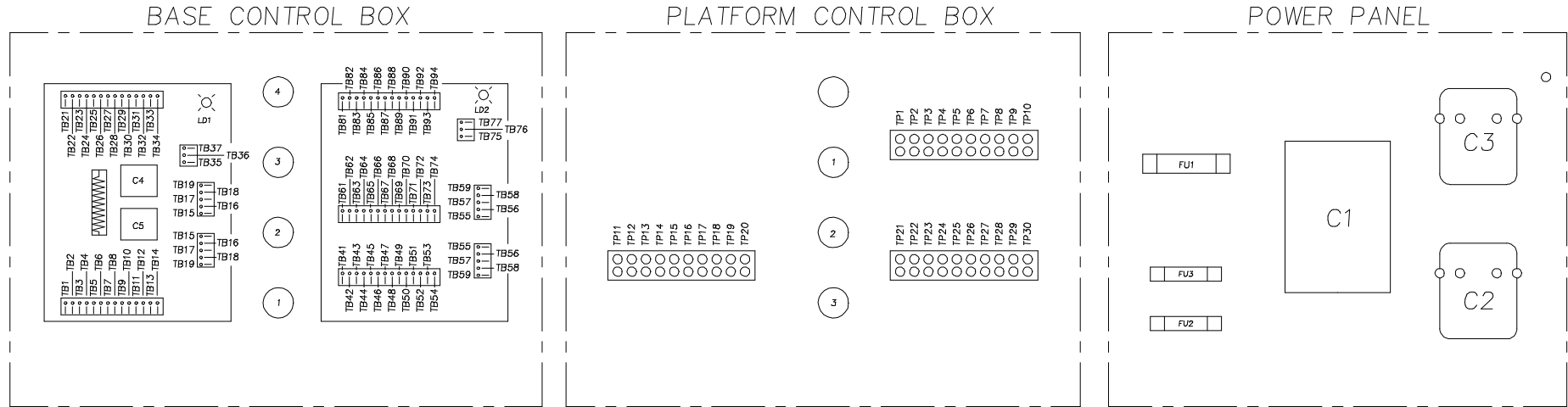

BP1	PROPORTNL CTL	OEM BOOM CONTROL	PLATFORM	S8	SOLENOID	BOOM REACH DOWN	CHASSIS
C1	36V RELAY	MOTOR/PUMP MASTER	CHASSIS	S9	SOLENOID	BOOM ELEVATE DOWN	CHASSIS
C2	36V RELAY	DRIVE PUMP MOTOR START	CHASSIS	S10	SOLENOID	BOOM ELEVATE DOWN	CHASSIS
C3	36V RELAY	BOOM PUMP MOTOR START	CHASSIS	S11	SOLENOID	BOOM REACH EXTEND	CHASSIS
C4	24V RELAY	CONTROL ACTIVATE	CHASSIS	S12	SOLENOID	BOOM REACH RETRACT	CHASSIS
C5	24V RELAY	HIGH/LOW SPEED SELECTION	CHASSIS	S13	SOLENOID	BOOM ELEVATE UP	CHASSIS
DP1	PROPORTNL CTL	OEM DRIVE & STEERING CONTROL	PLATFORM	S14	SOLENOID	BOOM REACH UP	CHASSIS
FG	GAGE	BATTERY CHARGE INDICATOR	PLATFORM	S15	SOLENOID	BOOM SWING LEFT	CHASSIS
FS1	FOOT SWITCH	POWER ON/OFF	PLATFORM	S16	SOLENOID	BOOM SWING RIGHT	CHASSIS
FU1	300 AMP FUSE	MASTER FUSE	CHASSIS	S17	SOLENOID	BOOM PROPORTIONAL SOLENOID	CHASSIS
FU2	10 AMP FUSE	AUXILIARY BOOM CIRCUIT	CHASSIS	S18	SOLENOID	PLATFORM LEVEL UP	CHASSIS
FU3	10 AMP FUSE	CONTROL CIRCUIT	CHASSIS	S19	SOLENOID	PLATFORM LEVEL DOWN	CHASSIS
H1	HORN	SERVICE HORN	CHASSIS	TB1-TB14	TERMINALS	INPUT TERMINALS P/N 45051	CHASSIS
H2	HORN	TRAVEL ALARM (OPTIONAL)	CHASSIS	TB15-TB19	TERMINALS	INPUT TERMINALS P/N 45051	CHASSIS
H3	HORN	TILT LEVEL INDICATOR	CHASSIS	TB35-TB37	TERMINALS	OUTPUT TERMINALS P/N 45051	CHASSIS
H4	HORN	DESCENT HORN (OPTIONAL)	CHASSIS	TB41-TB54	TERMINALS	INPUT TERMINALS P/N 45050	CHASSIS
HM	HOOR METER	RUNNING HOURS	CHASSIS	TB55-TB59	TERMINALS	INPUT TERMINALS P/N 45050	CHASSIS
KS1	KEY SWITCH	CHOOSE CONTROL LOCATION	CHASSIS	TB61-TB74	TERMINALS	INPUT TERMINALS P/N 45050	CHASSIS
LD1	LED	DRIVE FUNCTIONS	CHASSIS	TB75-TB77	TERMINALS	OUTPUT TERMINALS P/N 45051	CHASSIS
LD2	LED	BOOM FUCTIONS	CHASSIS	TB81-TB94	TERMINALS	OUTPUT TERMINALS P/N 45050	CHASSIS
LS1	LIMIT SWITCH	BOOM ELEV. VS. SPEED (SHOWN W/BOOM UP)	BOOM	TP21-TP34	TERMINALS	OUTPUT TERMINALS-PLATFORM CONTROL	PLATFORM
LS2	LIMIT SWITCH	SWING STOP	CHASSIS	TP1-TP14	TERMINALS	INPUT/OUTPUT TERMINALS-PLATFORM	PLATFORM
LS3	LIMIT SWITCH	SWING STOP	CHASSIS	TL1	LEVEL SWTCH	3.5 DEG. TILT LEVEL INDICATOR (NC)	CHASSIS
M1	MOTOR	DRIVE PUMP	CHASSIS	TS3	TOGGLE SWITCH	HIGH/LOW SPEED SELECTION	PLATFORM
M2	MOTOR	BOOM PUMP	CHASSIS	TS4	TOGGLE SWITCH	BOOM ELEV. UP/DOWN	PLATFORM
P1	PALM SWITCH	POWER ON/OFF	CHASSIS	TS5	TOGGLE SWITCH	BOOM SWING LEFT/RIGHT	PLATFORM
P2	PALM SWITCH	POWER ON/OFF	CHASSIS	TS6	TOGGLE SWITCH	BOOM REACH EXTEND/RETRACT	PLATFORM
P3	PALM SWITCH	HORN	PLATFORM	TS7	TOGGLE SWITCH	BOOM REACH UP/DOWN	PLATFORM
S1	SOLENOID	DRIVE PROPORTIONAL SOLENOID	CHASSIS	TS8	TOGGLE SWITCH	PLATFORM LEVEL UP/DOWN	PLATFORM
S2	SOLENOID	DRIVE SERIES MODE	CHASSIS	TS10	TOGGLE SWITCH	BOOM ELEV. UP/DOWN	CHASSIS
S3	SOLENOID	DRIVE SERIES MODE	CHASSIS	TS11	TOGGLE SWITCH	BOOM SWING LEFT/RIGHT	CHASSIS
S4	SOLENOID	STEER RIGHT	CHASSIS	TS12	TOGGLE SWITCH	BOOM REACH EXTEND/RETRACT	CHASSIS
S5	SOLENOID	STEER LEFT	CHASSIS	TS13	TOGGLE SWITCH	BOOM REACH UP/DOWN	CHASSIS
S6	SOLENOID	TRAVEL REVERSE	CHASSIS	TS14	TOGGLE SWITCH	PLATFORM LEVEL UP/DOWN	CHASSIS
S7	SOLENOID	TRAVEL FOWARD	CHASSIS	TS16	TOGGLE SWITCH	AUX. CONTROLS ELEV. DOWN/REACH RETR.	CHASSIS
				TS17	TOGGLE SWITCH	AUX. CONTROLS SWING LEFT/RIGHT	CHASSIS

Z45 DC KILOVOLT ELECTRICAL SCHEMATIC

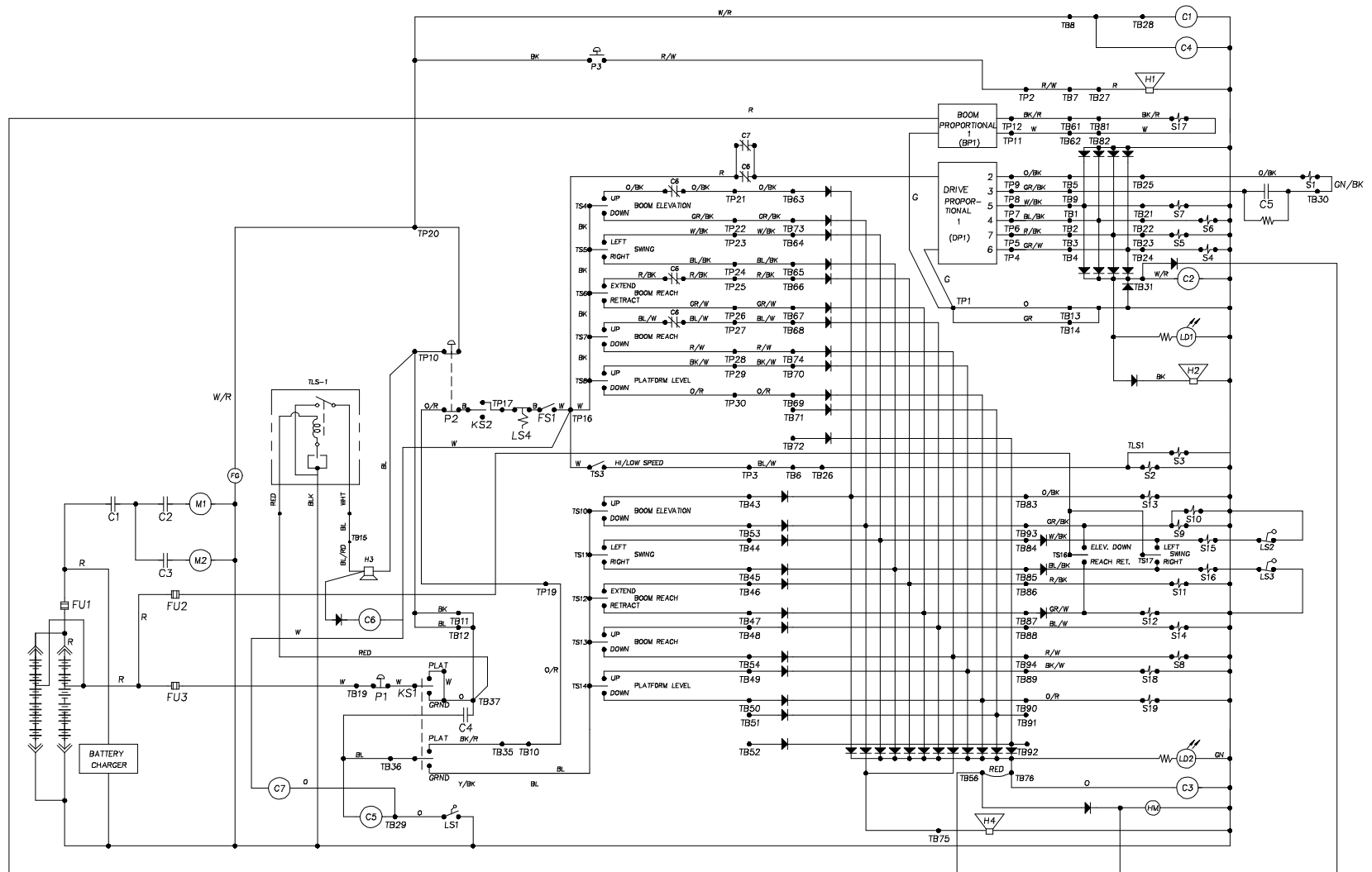

Z45DC KILOVTOV ELECTRICAL SCHEMATIC LEGEND

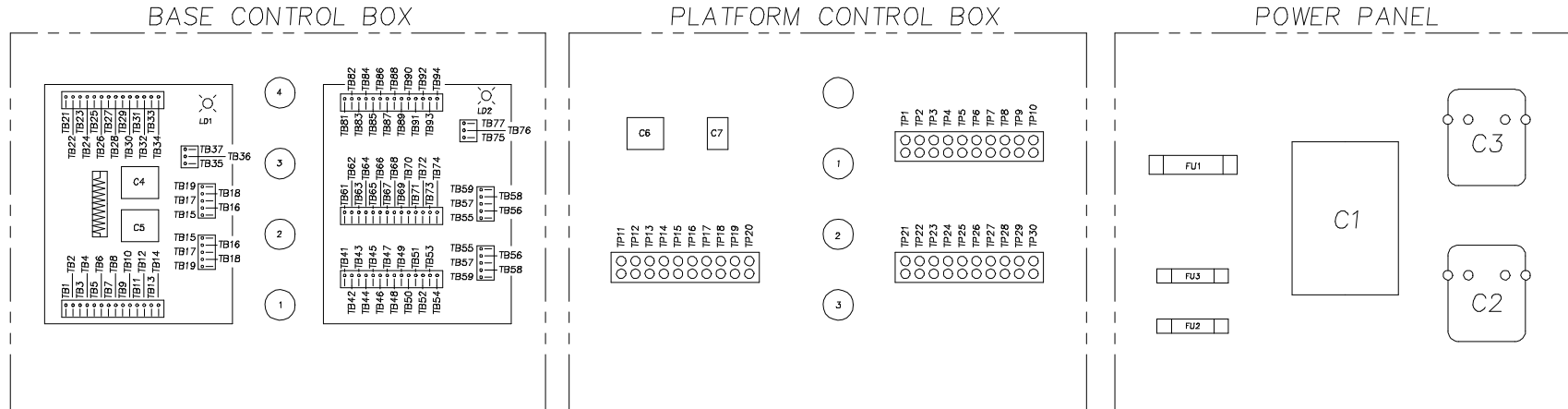

BP1	PROPERTNL CTL	OEM BOOM CONTROL	PLATFORM	S8	SOLENOID	BOOM REACH DOWN	CHASSIS
C1	36V RELAY	MOTOR/PUMP MASTER	CHASSIS	S9	SOLENOID	BOOM ELEVATE DOWN	CHASSIS
C2	36V RELAY	DRIVE PUMP MOTOR START	CHASSIS	S10	SOLENOID	BOOM ELEVATE DOWN	CHASSIS
C3	36V RELAY	BOOM PUMP MOTOR START	CHASSIS	S11	SOLENOID	BOOM REACH EXTEND	CHASSIS
C4	24V RELAY	CONTROL ACTIVATE	CHASSIS	S12	SOLENOID	BOOM REACH RETRACT	CHASSIS
C5	24V RELAY	HIGH/LOW SPEED SELECTION	CHASSIS	S13	SOLENOID	BOOM ELEVATE UP	CHASSIS
C6	24V RELAY	TILT BOOM FUNCTION RESTRICTION	PLATFORM	S14	SOLENOID	BOOM REACH UP	CHASSIS
C7	24V RELAY	TILT ALARM	PLATFORM	S15	SOLENOID	BOOM SWING LEFT	CHASSIS
DP1	PROPERTNL CTL	OEM DRIVE & STEERING CONTROL	PLATFORM	S16	SOLENOID	BOOM SWING RIGHT	CHASSIS
FG	GAGE	BATTERY CHARGE INDICATOR	PLATFORM	S17	SOLENOID	BOOM PROPORTIONAL SOLENOID	CHASSIS
FS1	FOOT SWITCH	POWER ON/OFF	PLATFORM	S18	SOLENOID	PLATFORM LEVEL UP	CHASSIS
FU1	300 AMP FUSE	MASTER FUSE	CHASSIS	S19	SOLENOID	PLATFORM LEVEL DOWN	CHASSIS
FU2	10 AMP FUSE	AUXILIARY BOOM CIRCUIT	CHASSIS	TB1-TB14	TERMINALS	INPUT TERMINALS P/N 45051	CHASSIS
FU3	10 AMP FUSE	CONTROL CIRCUIT	CHASSIS	TB15-TB19	TERMINALS	INPUT TERMINALS P/N 45051	CHASSIS
H1	HORN	SERVICE HORN	CHASSIS	TB35-TB37	TERMINALS	OUTPUT TERMINALS P/N 45051	CHASSIS
H2	HORN	TRAVEL ALARM (OPTIONAL)	CHASSIS	TB41-TB54	TERMINALS	INPUT TERMINALS P/N 45050	CHASSIS
H3	HORN	TILT LEVEL INDICATOR	CHASSIS	TB55-TB59	TERMINALS	INPUT TERMINALS P/N 45050	CHASSIS
H4	HORN	DESCENT HORN (OPTIONAL)	CHASSIS	TB61-TB74	TERMINALS	INPUT TERMINALS P/N 45050	CHASSIS
HM	HOOR METER	RUNNING HOURS	CHASSIS	TB75-TB77	TERMINALS	OUTPUT TERMINALS P/N 45051	CHASSIS
KS1	KEY SWITCH	CHOOSE CONTROL LOCATION	CHASSIS	TB81-TB94	TERMINALS	OUTPUT TERMINALS P/N 45050	CHASSIS
KS2	KEY SWITCH	PLATFORM ON/OFF	PLATFORM	TP21-TP34	TERMINALS	OUTPUT TERMINALS-PLATFORM	PLATFORM
LD1	LED	DRIVE FUNCTIONS	CHASSIS	TP1-TP14	TERMINALS	INPUT/OUTPUT TERMINALS-PLATFORM	PLATFORM
LD2	LED	BOOM FUCTIONS	CHASSIS	TL51	LEVEL SWITCH	3.5 DEG. TILT LEVEL INDICATOR (NC)	CHASSIS
LS1	LIMIT SWITCH	BOOM ELEV. VS. SPEED (SHOWN W/BOOM UP)	BOOM	TS3	TOGGLE SWITCH	HIGH/LOW SPEED SELECTION	PLATFORM
LS2	LIMIT SWITCH	SWING STOP	CHASSIS	TS4	TOGGLE SWITCH	BOOM ELEV. UP/DOWN	PLATFORM
LS3	LIMIT SWITCH	SWING STOP	CHASSIS	TS5	TOGGLE SWITCH	BOOM SWING LEFT/RIGHT	PLATFORM
LS4	LIMIT SWITCH	DOOR INTERLOCK	PLATFORM	TS6	TOGGLE SWITCH	BOOM REACH EXTEND/RETRACT	PLATFORM
M1	MOTOR	DRIVE PUMP	CHASSIS	TS7	TOGGLE SWITCH	BOOM REACH UP/DOWN	PLATFORM
M2	MOTOR	BOOM PUMP	CHASSIS	TS8	TOGGLE SWITCH	PLATFORM LEVEL UP/DOWN	PLATFORM
P1	PALM SWITCH	POWER ON/OFF	CHASSIS	TS10	TOGGLE SWITCH	BOOM ELEV. UP/DOWN	CHASSIS
P2	PALM SWITCH	POWER ON/OFF	PLATFORM	TS11	TOGGLE SWITCH	BOOM SWING LEFT/RIGHT	CHASSIS
P3	PALM SWITCH	HORN	PLATFORM	TS12	TOGGLE SWITCH	BOOM REACH EXTEND/RETRACT	CHASSIS
S1	SOLENOID	DRIVE PROPORTIONAL SOLENOID	CHASSIS	TS13	TOGGLE SWITCH	BOOM REACH UP/DOWN	CHASSIS
S2	SOLENOID	DRIVE SERIES MODE	CHASSIS	TS14	TOGGLE SWITCH	PLATFORM LEVEL UP/DOWN	CHASSIS
S3	SOLENOID	DRIVE SERIES MODE	CHASSIS	TS16	TOGGLE SWITCH	AUX. CONTROLS ELEV. DOWN/REACH RETR.	CHASSIS
S4	SOLENOID	STEER RIGHT	CHASSIS	TS17	TOGGLE SWITCH	AUX. CONTROLS SWING LEFT/RIGHT	CHASSIS
S5	SOLENOID	STEER LEFT	CHASSIS				
S6	SOLENOID	TRAVEL REVERSE	CHASSIS				
S7	SOLENOID	TRAVEL FOWARD	CHASSIS				

Z45/22 MP DC ELECTRICAL SCHEMATIC WITH CR1, CR2, & CR3 CONTROL RELAYS

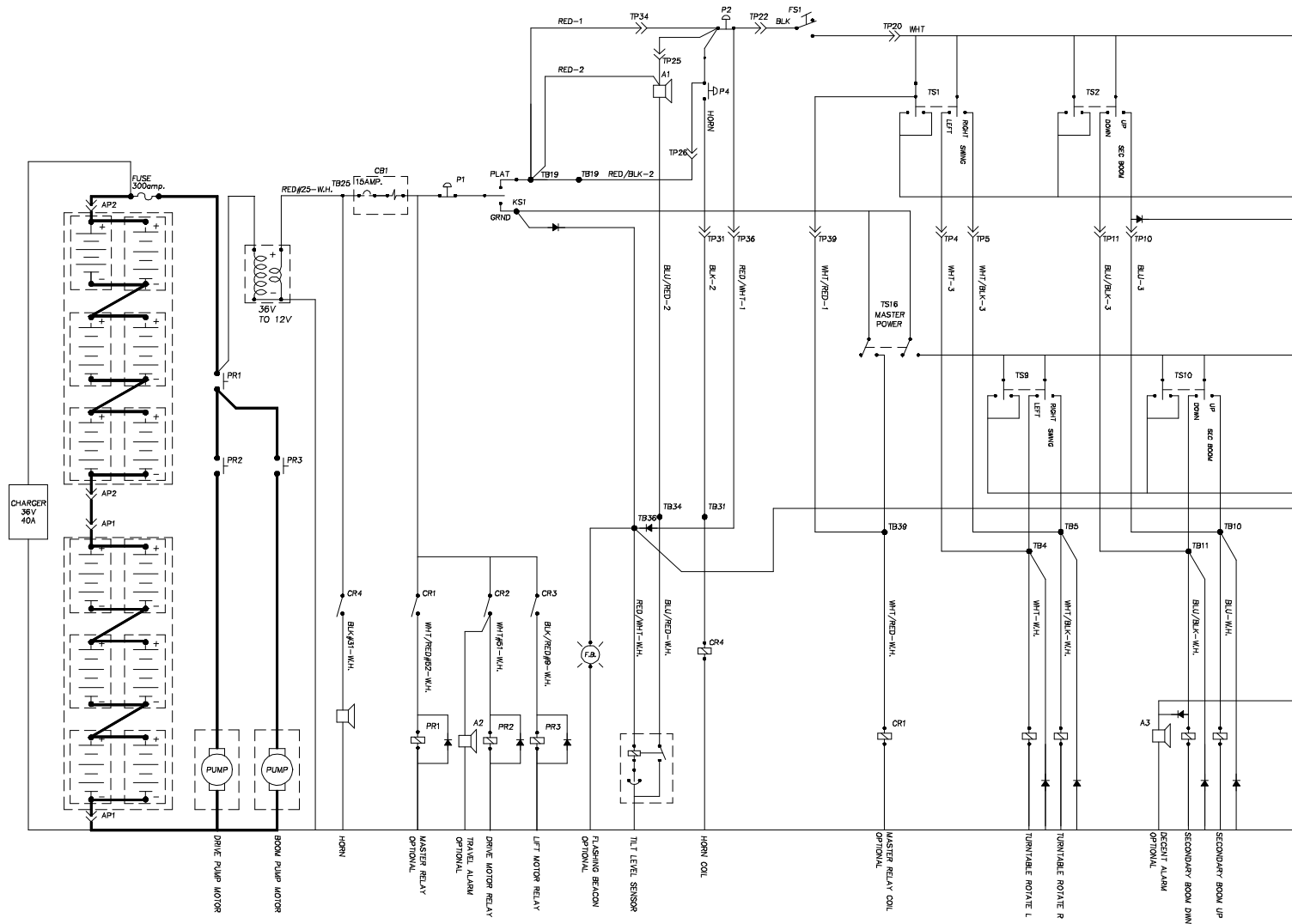

Z45/22 MP DC
 ELECTRICAL SCHEMATIC (cont'd)
 WITH CR1, CR2 & CR3 CONTROL RELAYS

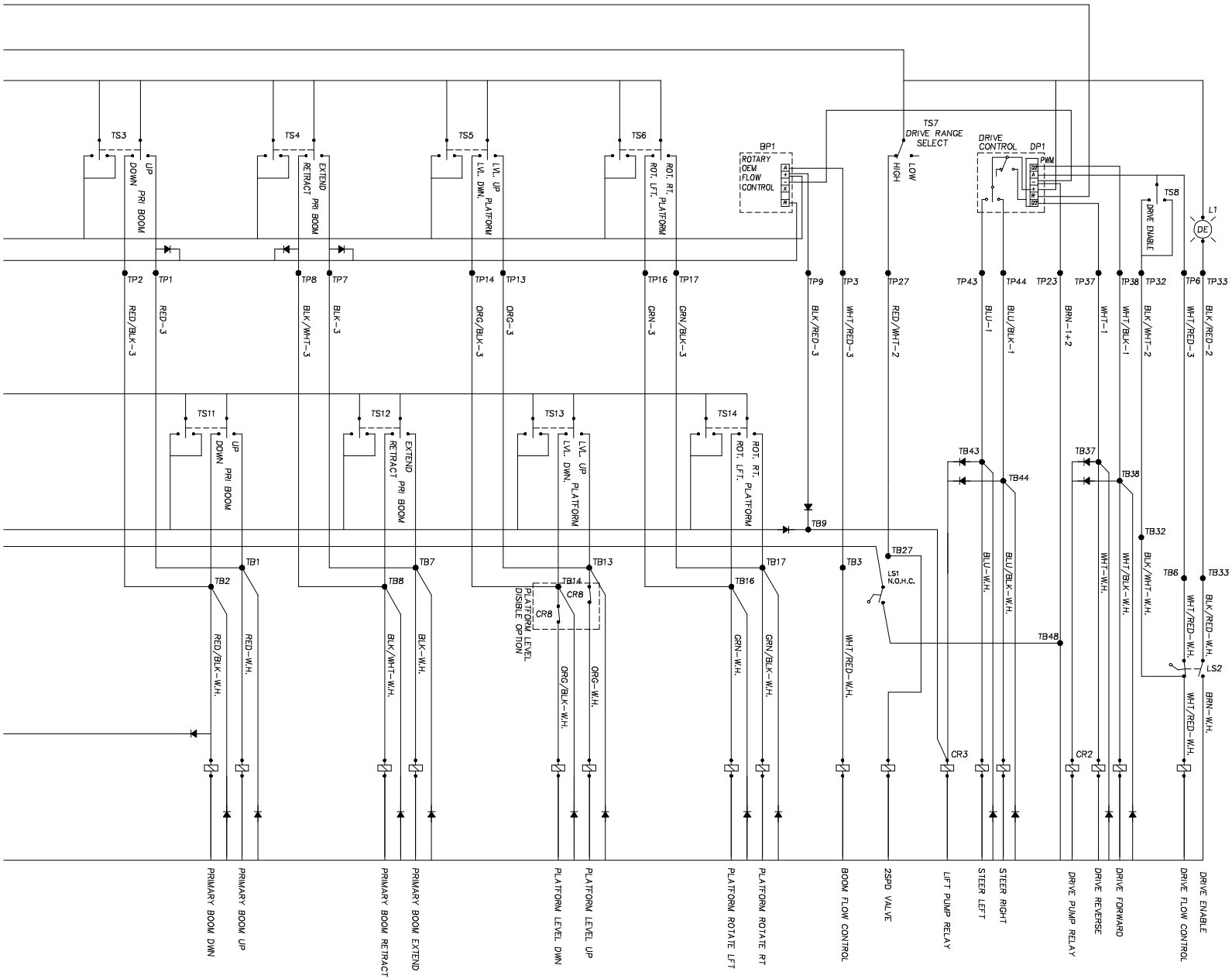

Z45/22 MP DC
RELAY PANEL LEGEND
WITH CR1, CR2 & CR3 CONTROL RELAYS

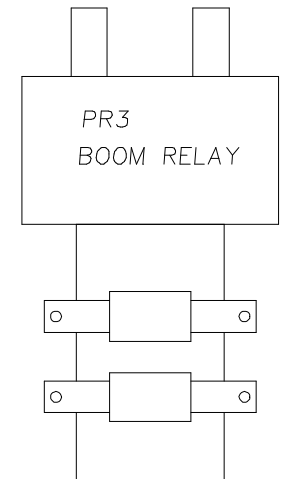
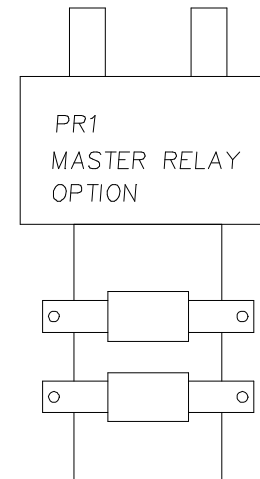
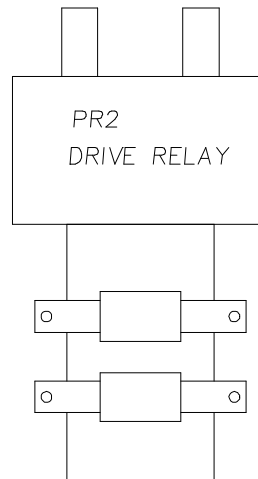
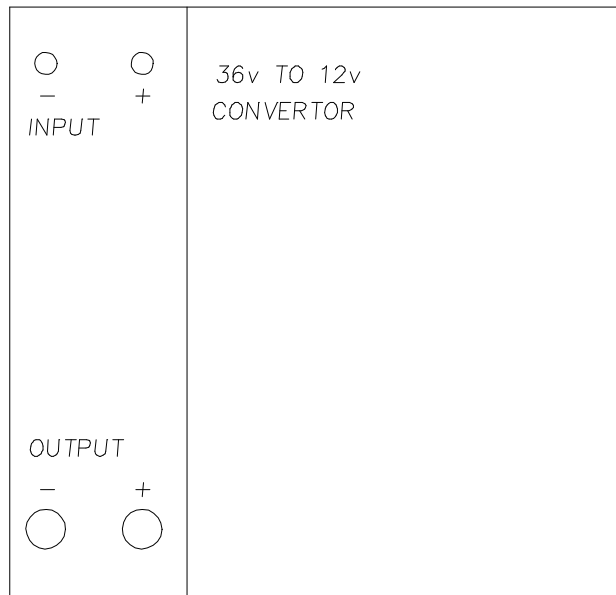

Z45/22 MP DC GROUND CONTROL BOX LEGEND WITH CR1, CR2 & CR3 CONTROL RELAYS

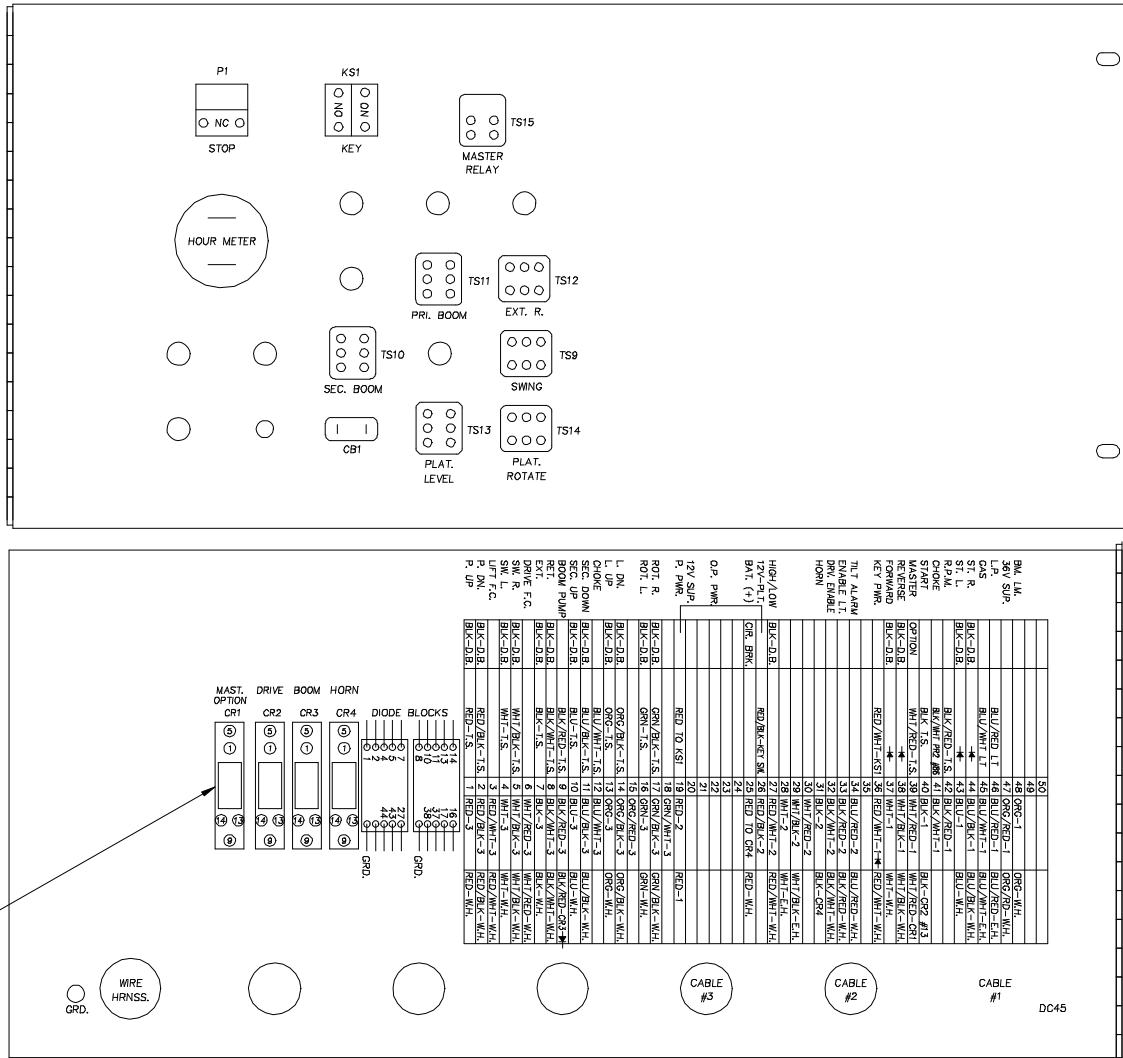

Z45/22 MP DC
 PLATFORM CONTROL BOX LEGEND
 WITH CR1, CR2 & CR3 CONTROL RELAYS

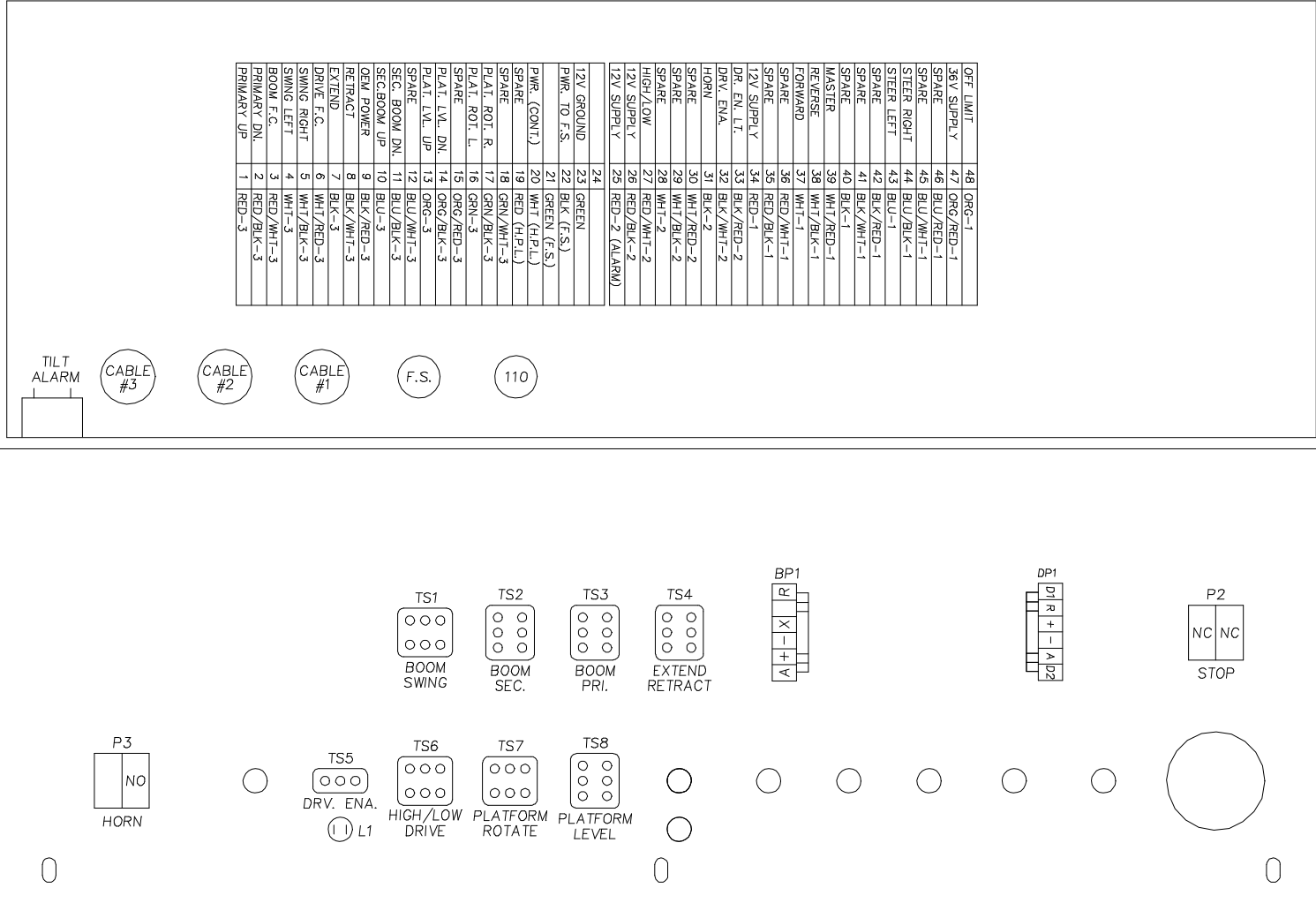

Z45/22 MP DC
ELECTRICAL SCHEMATIC
WITHOUT CR1, CR2 & CR3 CONTROL RELAYS

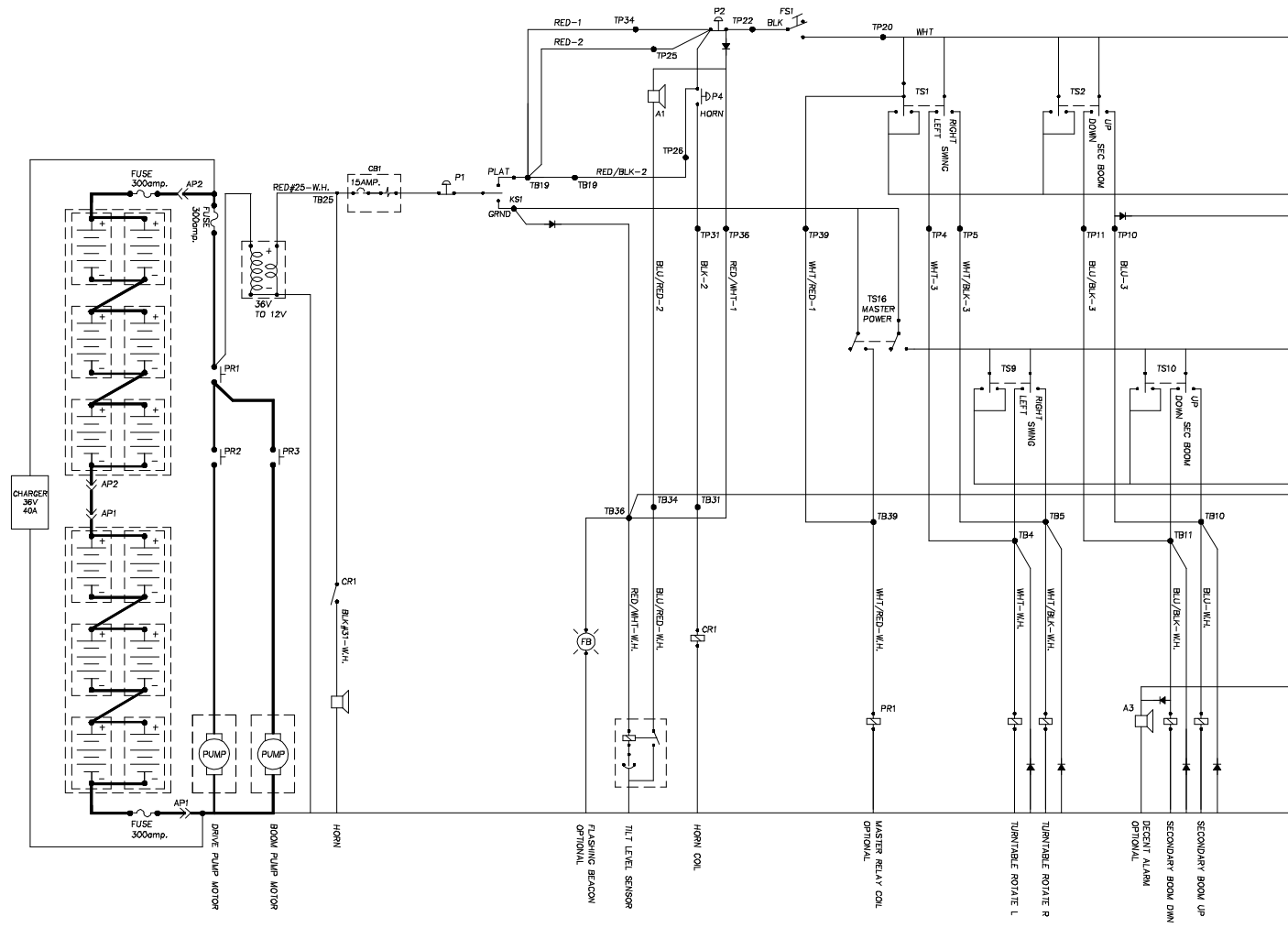

Z45/22 MP DC
 ELECTRICAL SCHEMATIC (cont'd)
 WITHOUT CR1, CR2 & CR3 CONTROL RELAYS

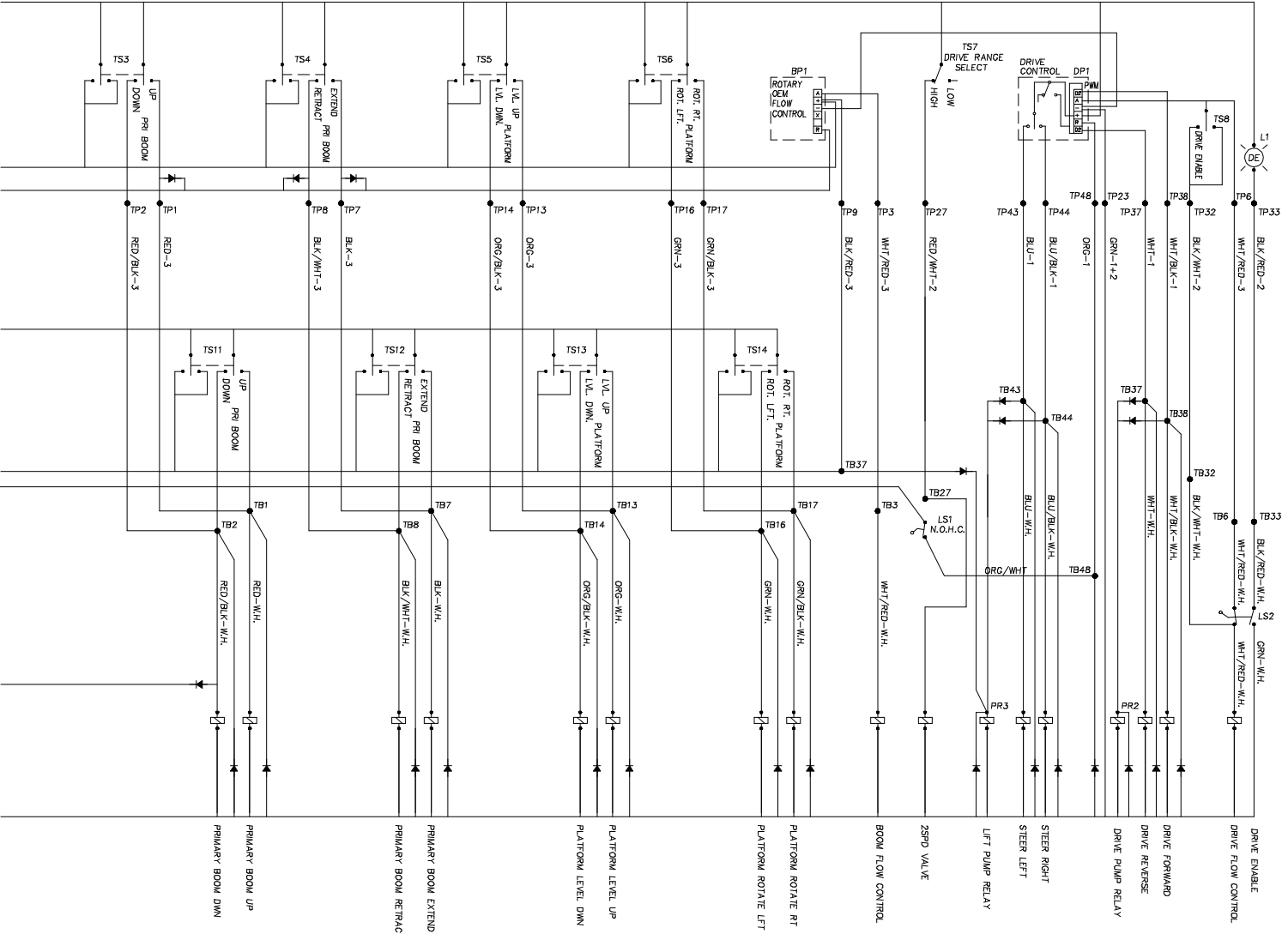

Z45/22 MP DC
RELAY PANEL LEGEND
WITHOUT CR1, CR2 & CR3 CONTROL RELAYS

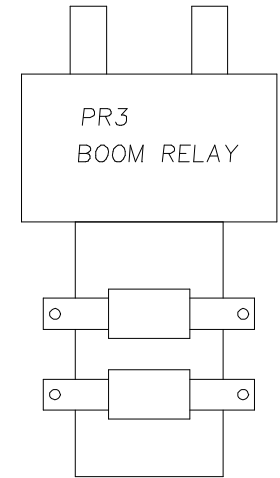
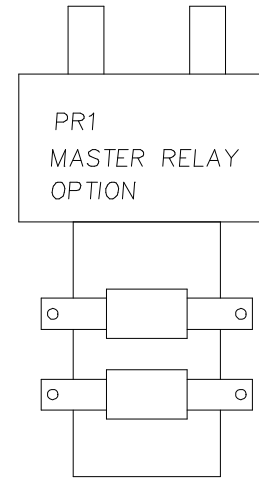
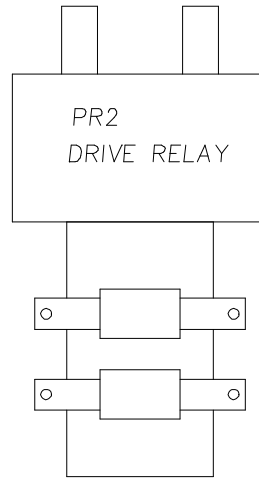
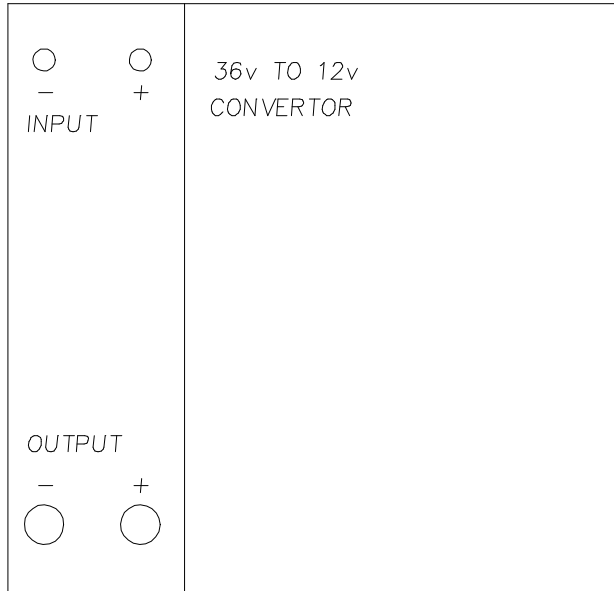

Z45/22 MP DC
GROUND CONTROL BOX LEGEND
WITHOUT CR1, CR2 & CR3 CONTROL RELAYS

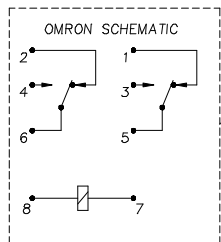
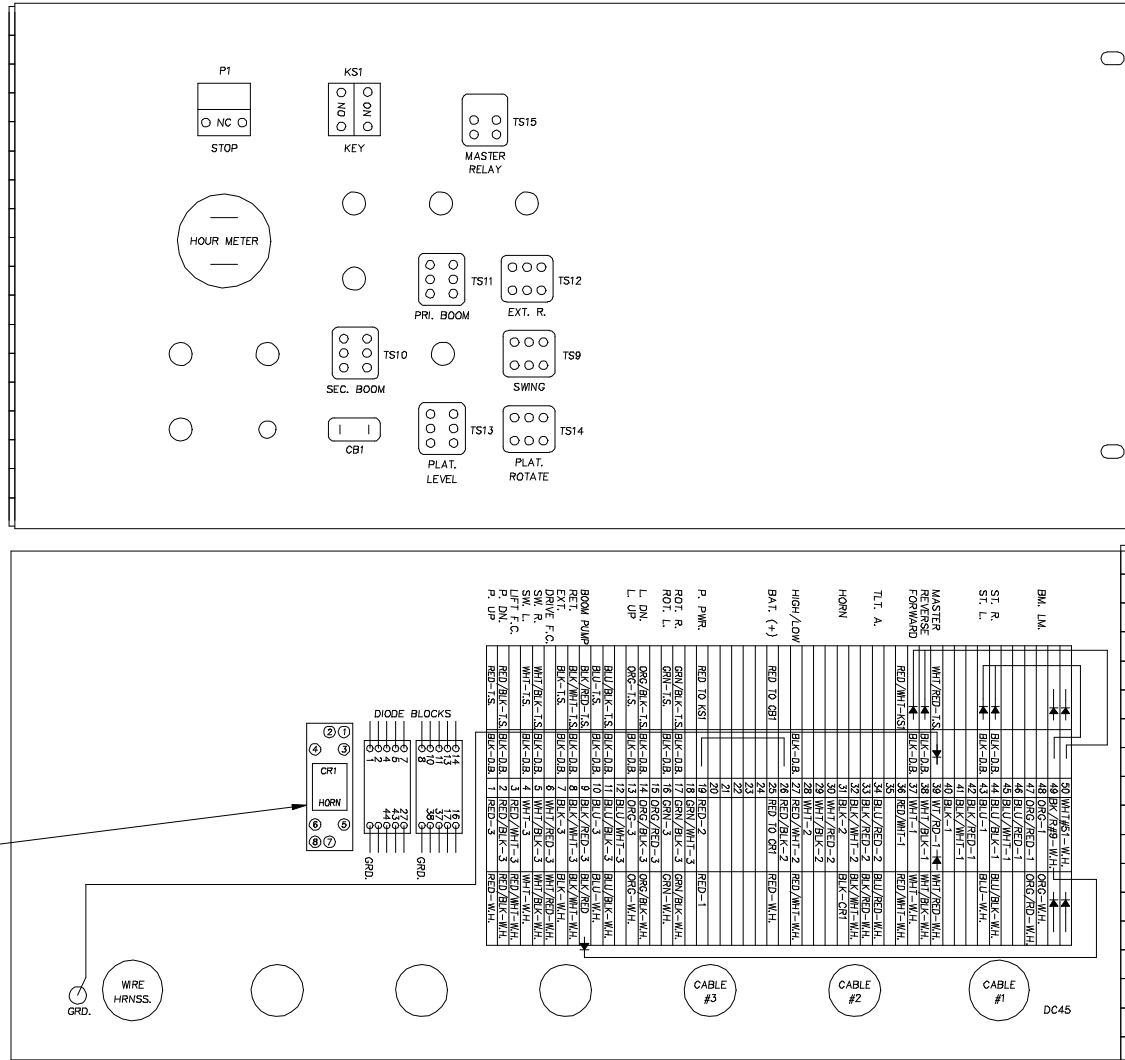

Z45/22 MP DC
 PLATFORM CONTROL BOX LEGEND
 WITHOUT CR1, CR2 & CR3 CONTROL RELAYS

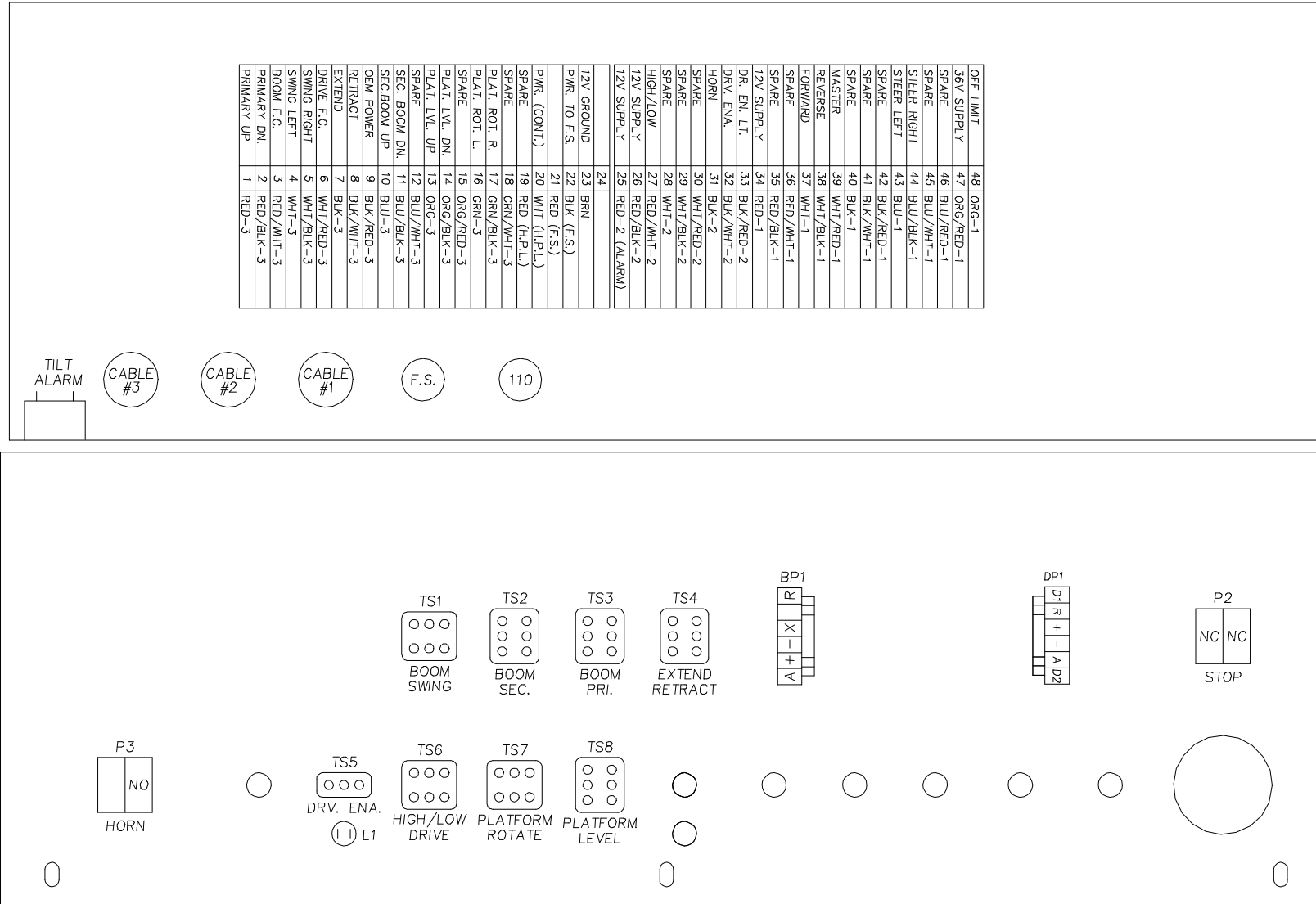

Z45/22 MP DC
ELECTRICAL SCHEMATIC
WITH FUNCTION ENABLE

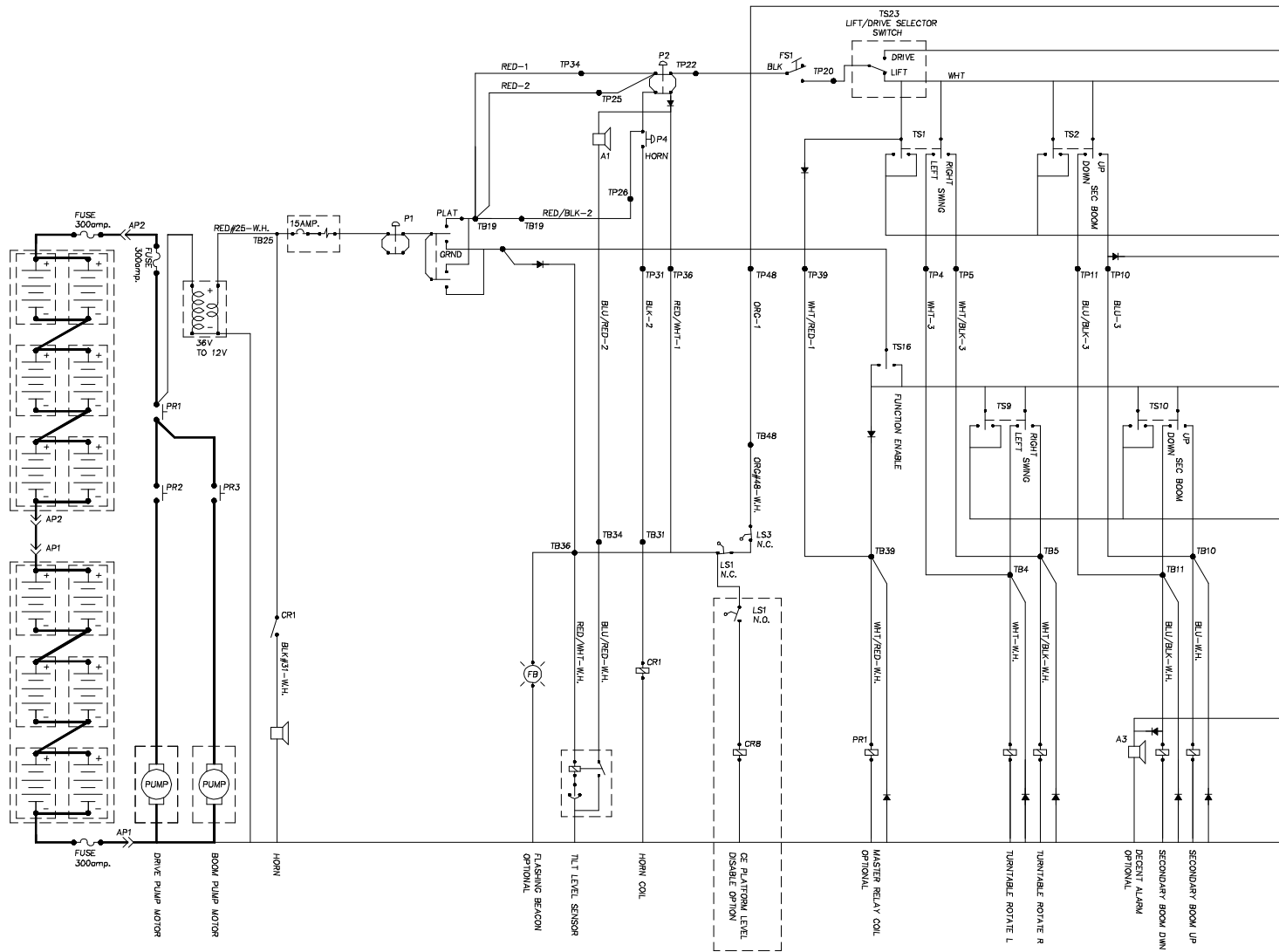

Z45/22 MP DC
ELECTRICAL SCHEMATIC (cont'd)
WITH FUNCTION ENABLE

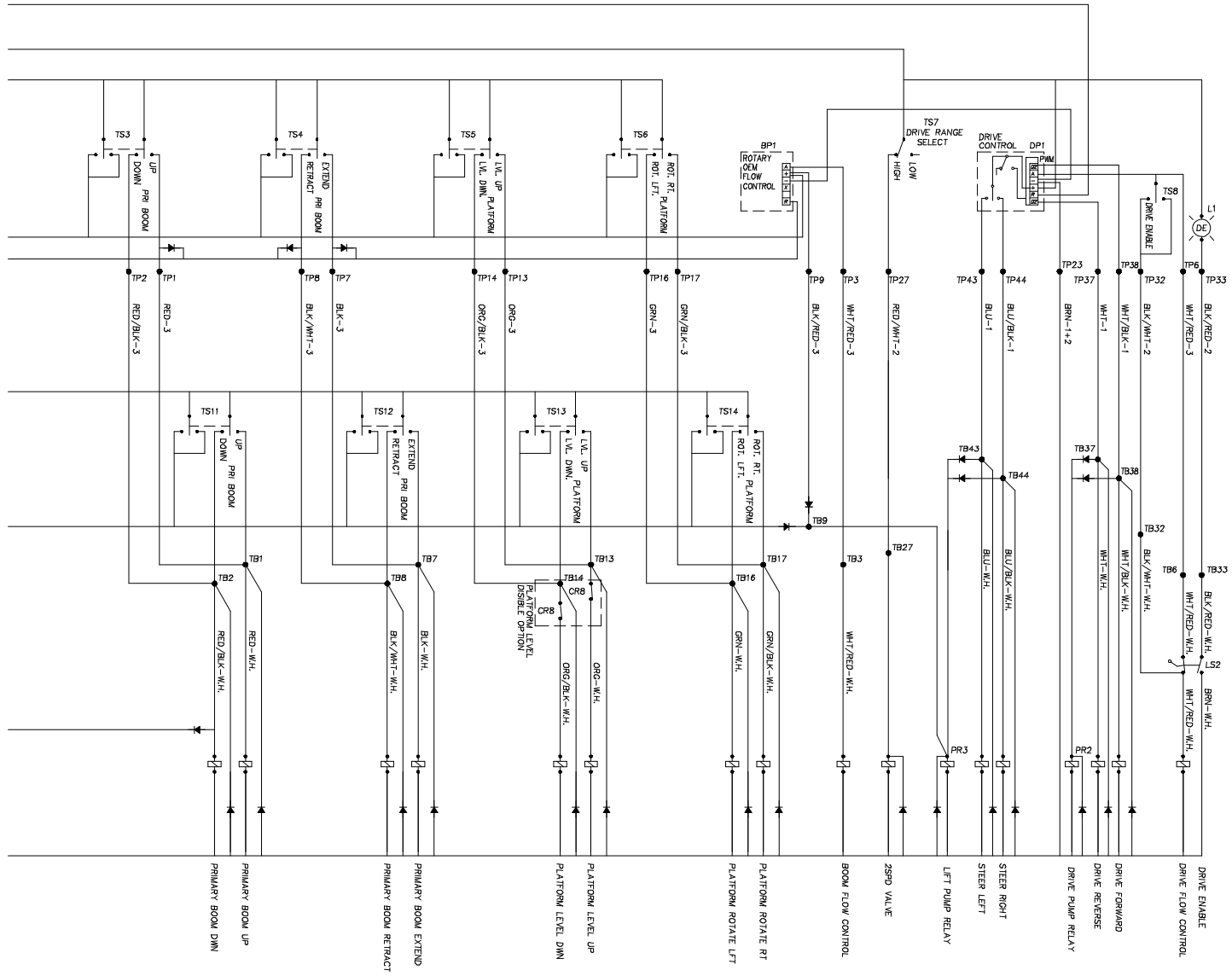

Z45/22 MP DC
RELAY PANEL
WITH FUNCTION ENABLE

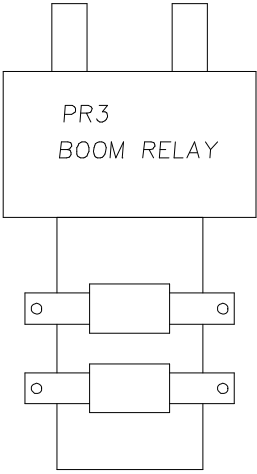
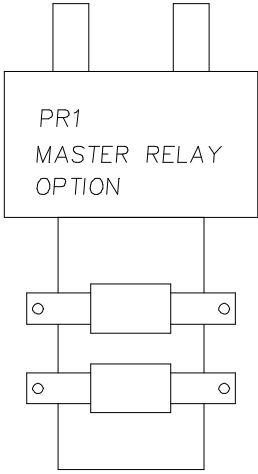
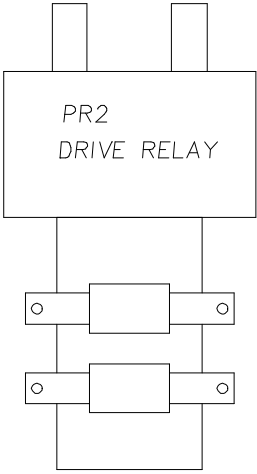
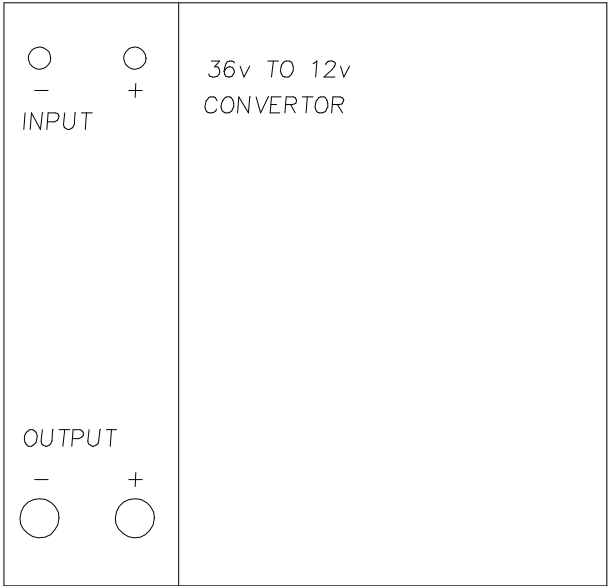

Z45/22 MP DC
GROUND CONTROL BOX LEGEND
WITH FUNCTION ENABLE

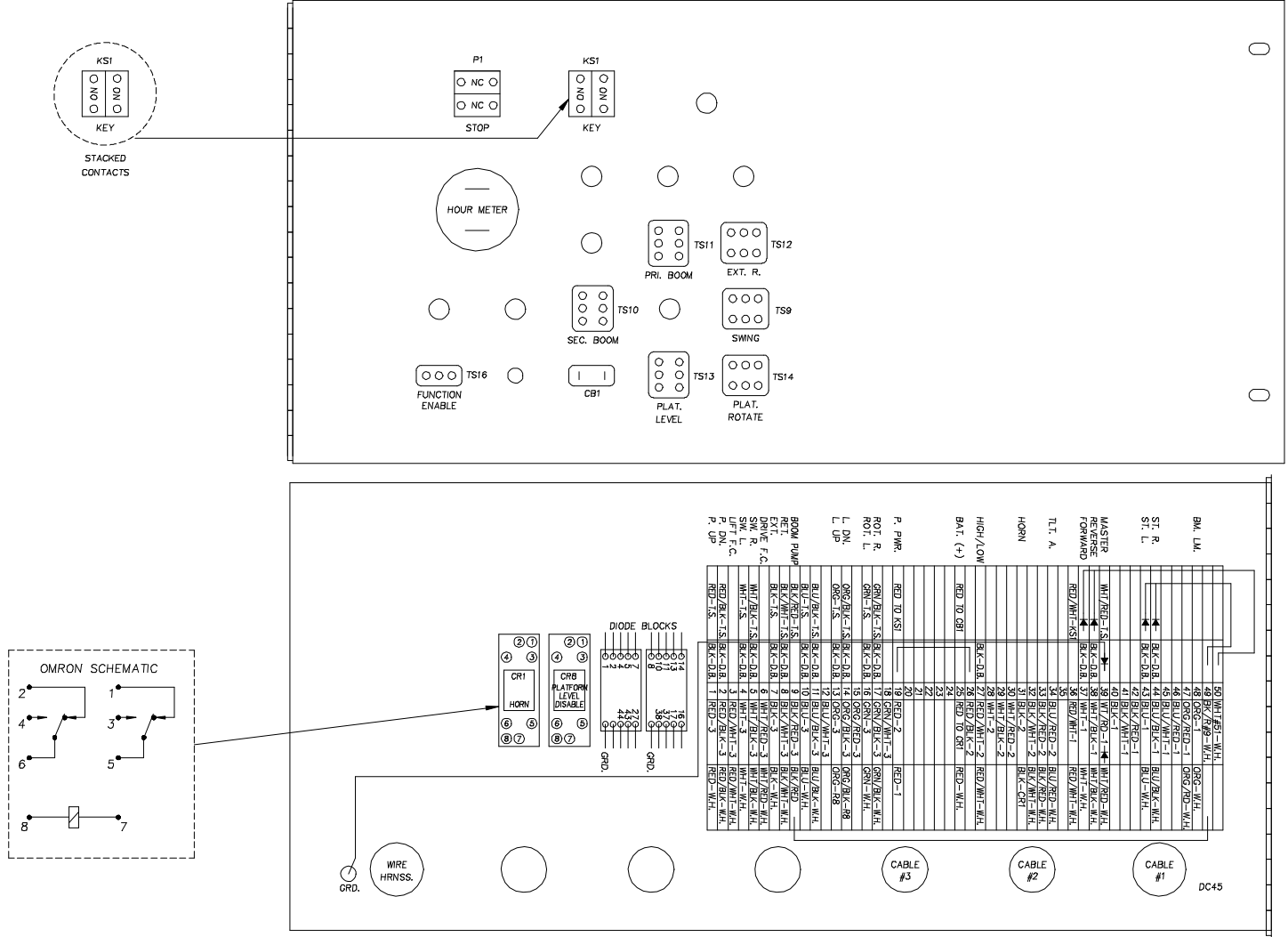

Z45/22 MP DC
 PLATFORM CONTROL BOX LEGEND
 WITH FUNCTION ENABLE

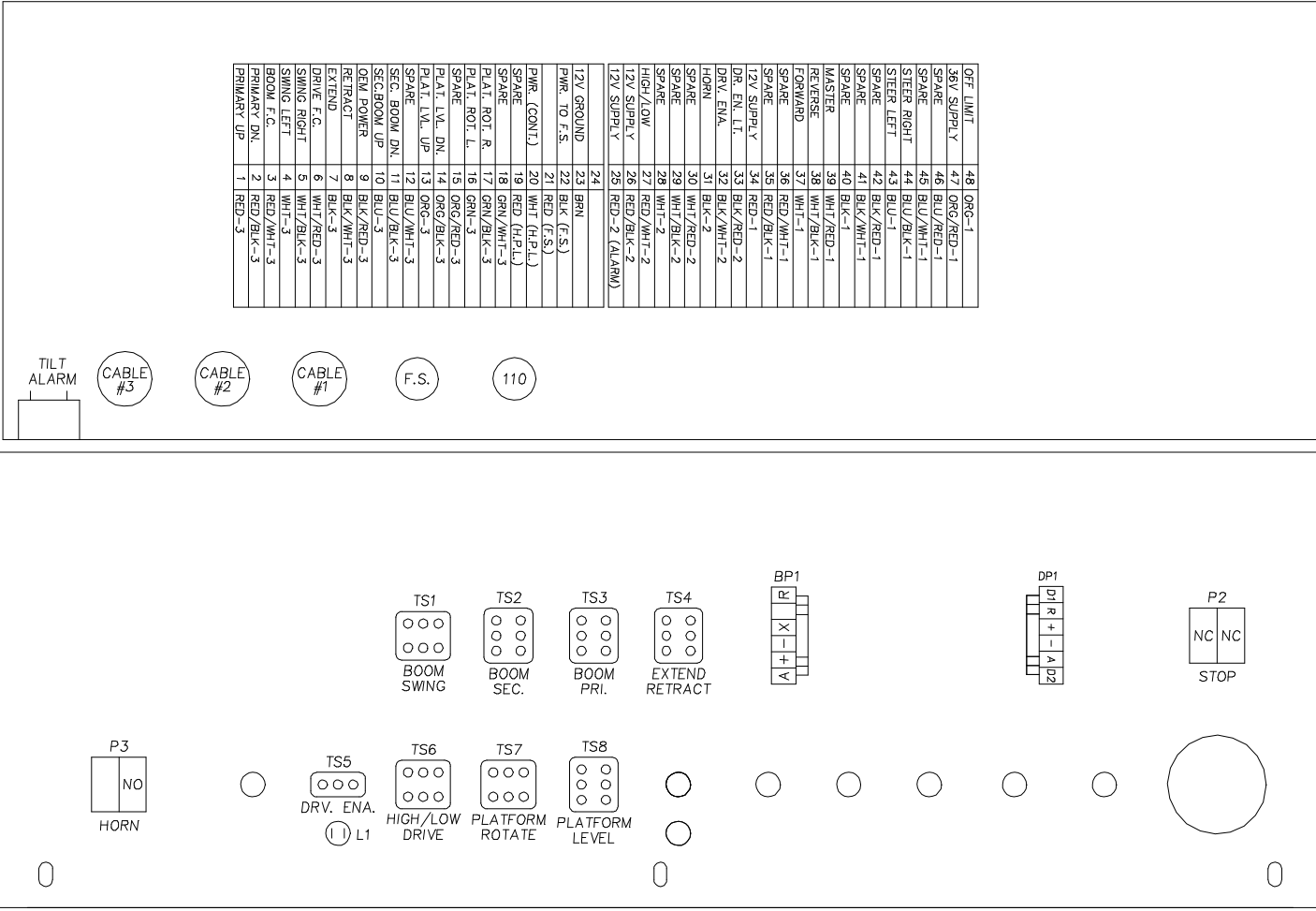

Z45/22 DC 2WD
ELECTRICAL SCHEMATIC (cont'd)
SERIAL # Z45-4916 & ABOVE

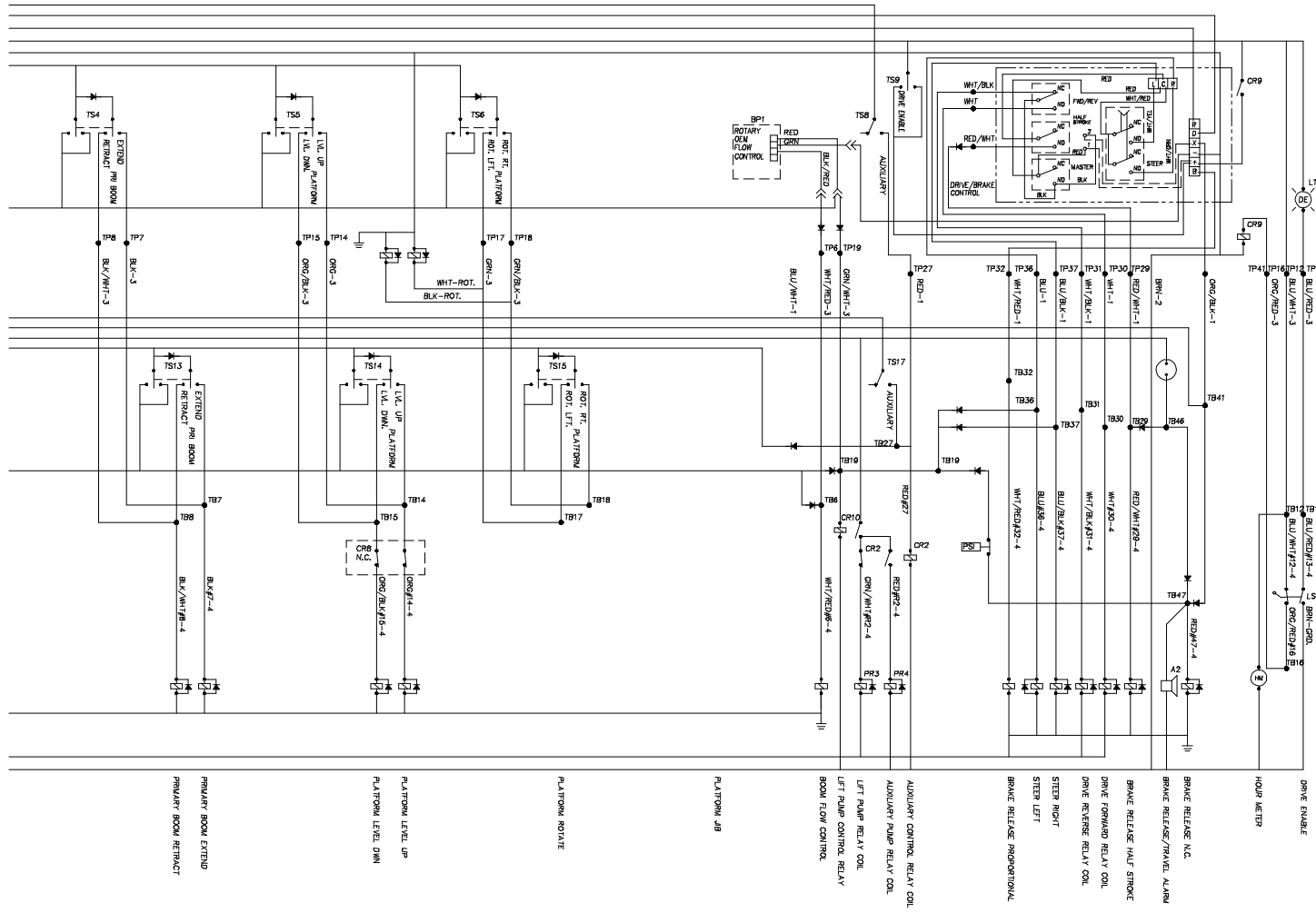

LABEL	DESCRIPTION
A	ALARM
AP	ANDERSON PLUG
BP	BOOM PROPORTIONAL CONTROLLER
CB	CIRCUIT BREAKER
CR	CONTROL RELAY
DE	DRIVE ENABLE
DP	DRIVE PROPORTIONAL CONTROLLER
FB	FLASHING BEACON
FS	FOOT SWITCH
HM	HOOR METER
LS	LIMIT SWITCH
P	POWER SWITCH
PR	POWER RELAY
PS	PRESSURE SWITCH
TB	TERMINAL BASE LOCATION
TS	TOGGLE SWITCH
B.C.I.	BATTERY CHARGE INDICATOR
L.V.I.	LOW VOLTAGE INTERRUPT

Z45/22 DC 2WD
 ELECTRICAL SCHEMATIC
 PLATFORM CONTROL BOX
 SERIAL # Z45-4916 & ABOVE

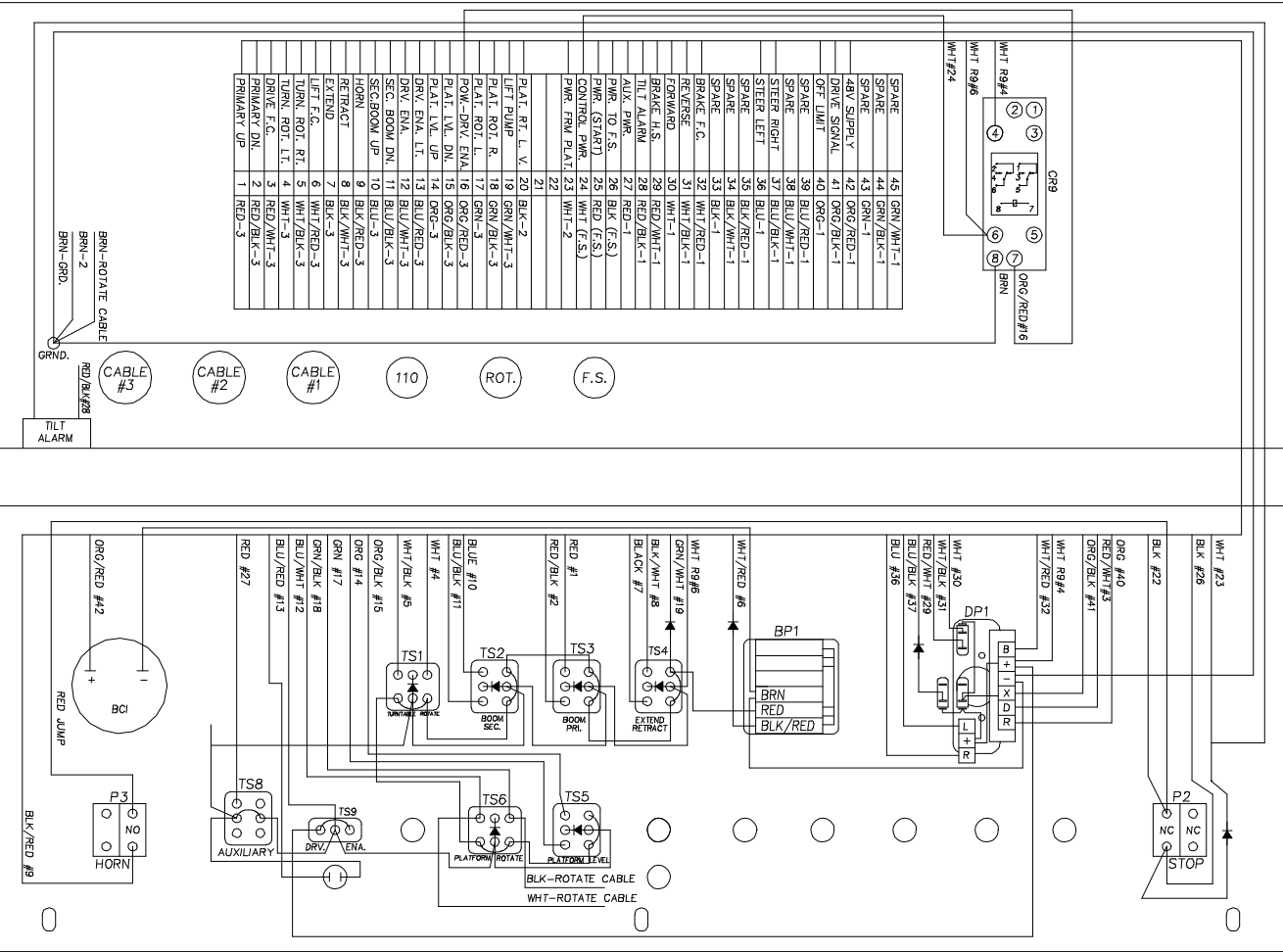

Z45/22 DC
ELECTRICAL SCHEMATIC
LIFT/DRIVE SELECT
WITH LVI BCI OPTION

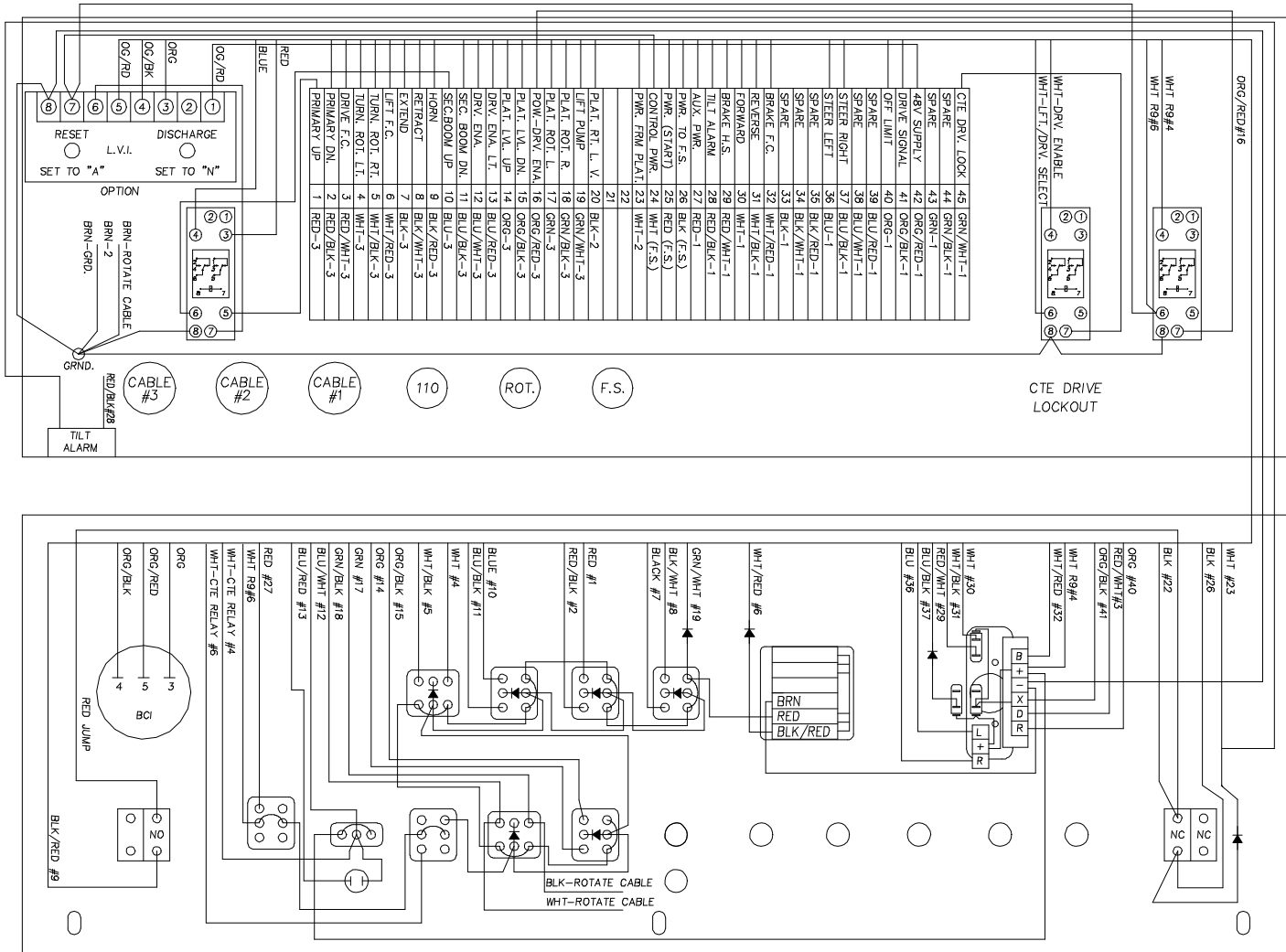

Z45/22 DC 2WD
 ELECTRICAL SCHEMATIC
 GROUND CONTROL BOX
 SERIAL # Z45-4916 & ABOVE

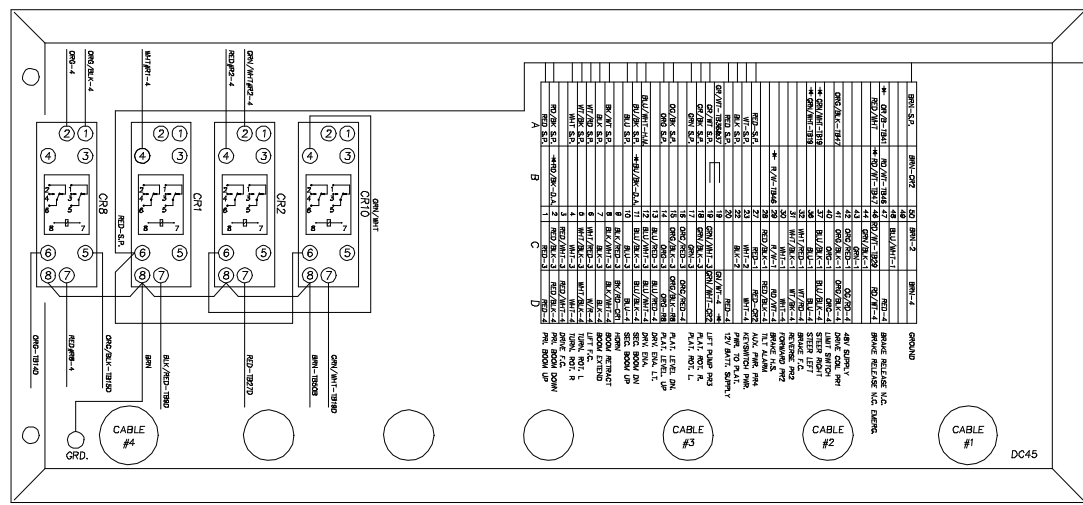
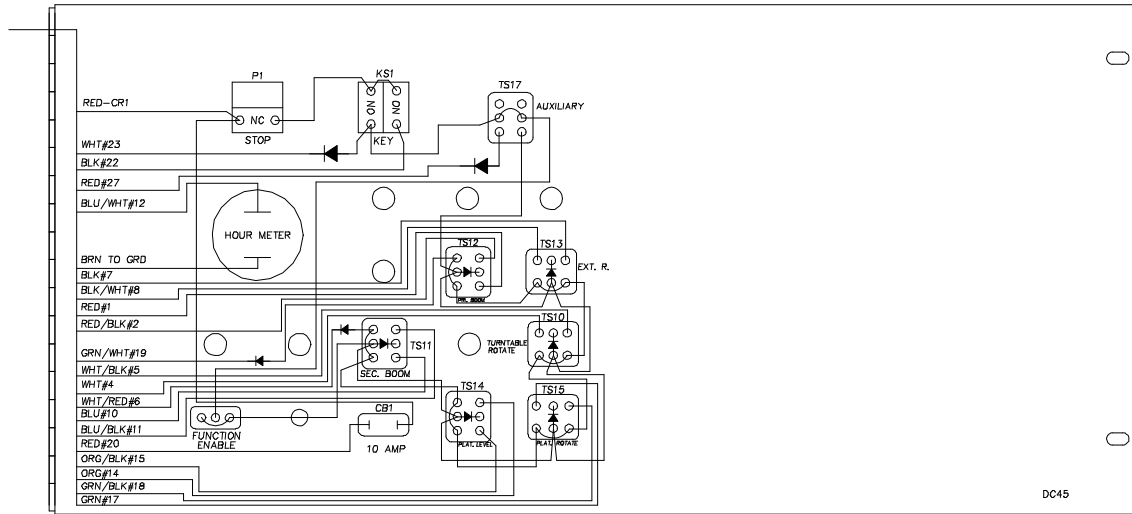

Z45/22 DC MANIFOLD ELECTRICAL CONNECTIONS

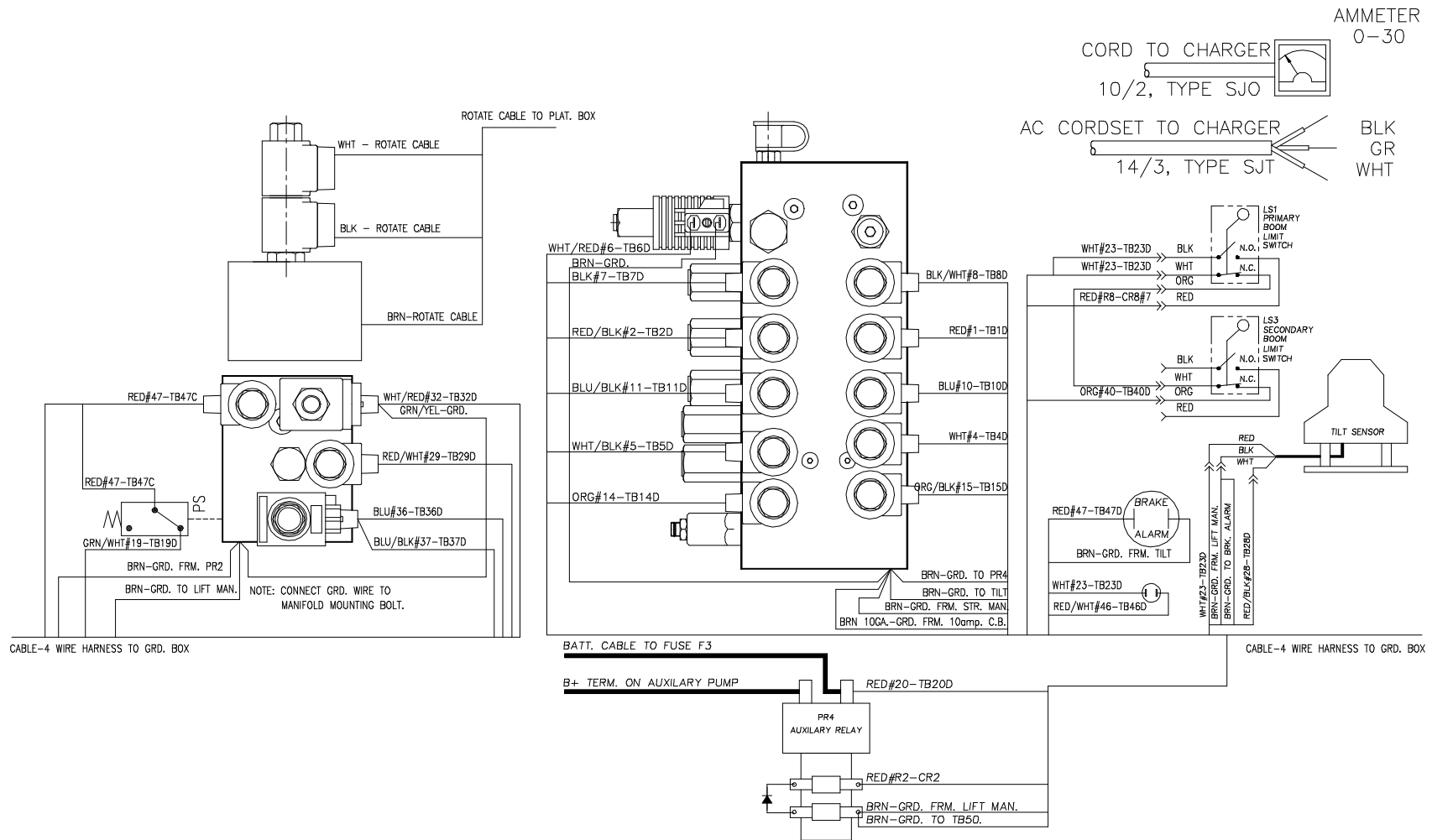

Z45/22 DC
 HYDRAULIC SCHEMATIC
 SERIAL# 4588-1550 AND ABOVE

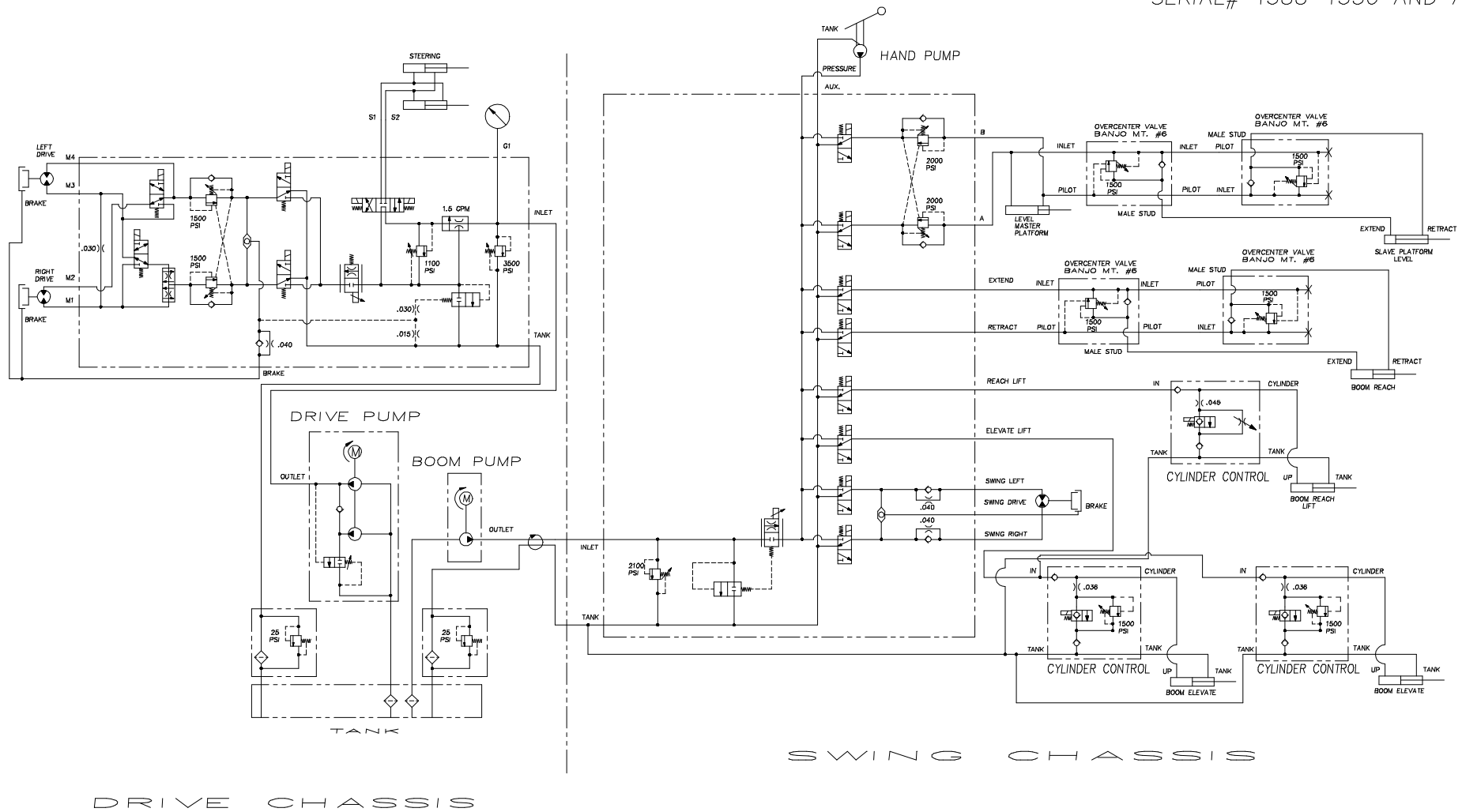

DRIVE CHASSIS

SWING CHASSIS

Z45/22 DC
 DRIVE FUNCTION HYDRAULIC SCHEMATIC
 WITH SUNSTRAND PISTON WHEEL MOTOR
 SERIAL # 4588-1550 & ABOVE

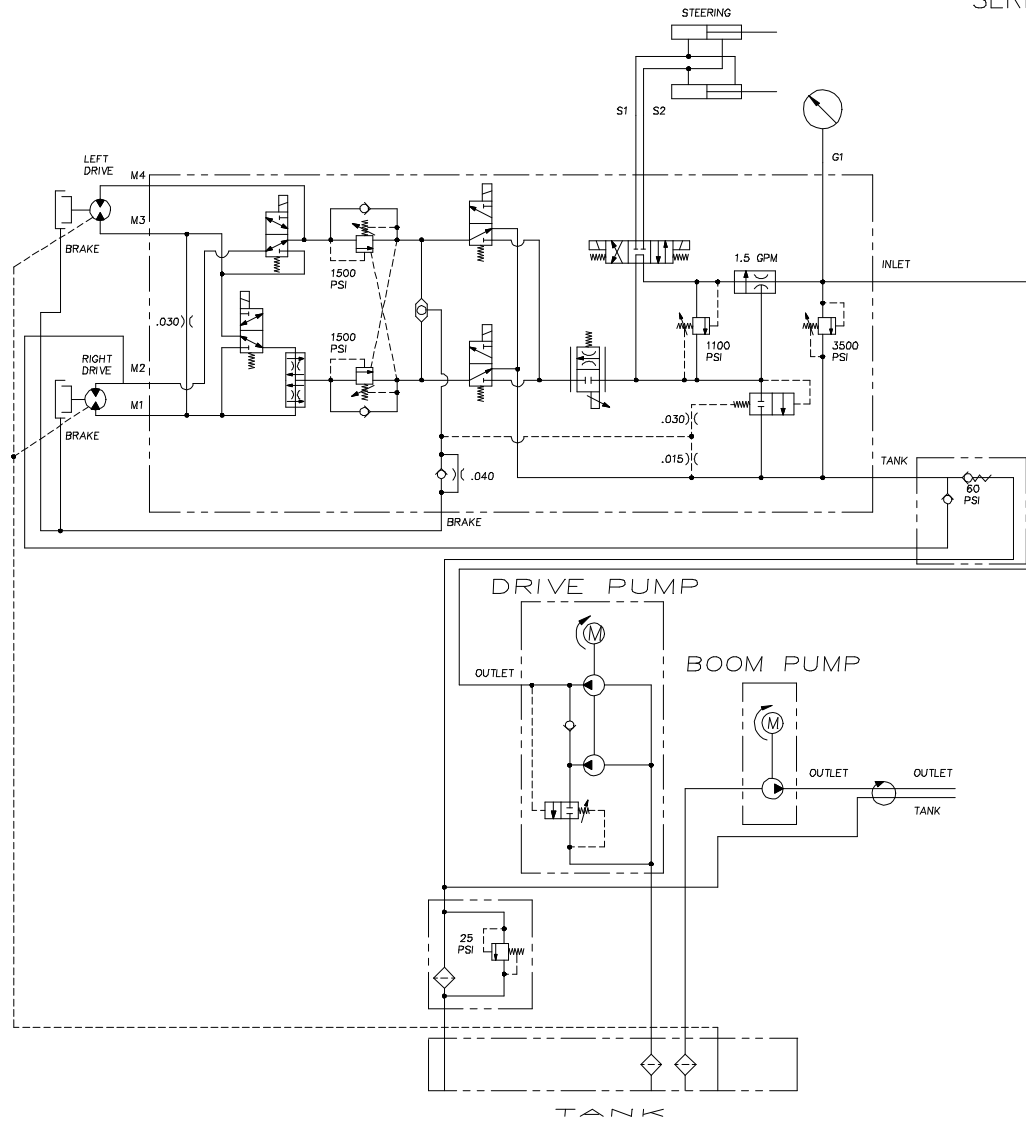

Z45/22 DC
 LIFT FUNCTION MANIFOLD DRAWING/LEGEND
 SERIAL # 4588-1550 & ABOVE

1	45490	2 POSITION 3 WAY SOLENOID / CP520-1-B-0-20D-S	8
2	45491	RELIEF VALVE / CP200-1-B-0-A-C-200	3
3	23938	CHECK VALVE / CP100-1-B-0-0015	2
4	45483	MINI SHUTTLE VALVE / 920067	1
5	45492	N.C. VARIABLE ORIFICE / CP550-30-B-0-3G-24D-S	1
6	45493	DIFF. SENSING VALVE / CP700-1-B-0-100	1
7	45642	DIAGNOSTIC NIPPLE - 320772	1
8	45643	DUST CAP - 320773	1

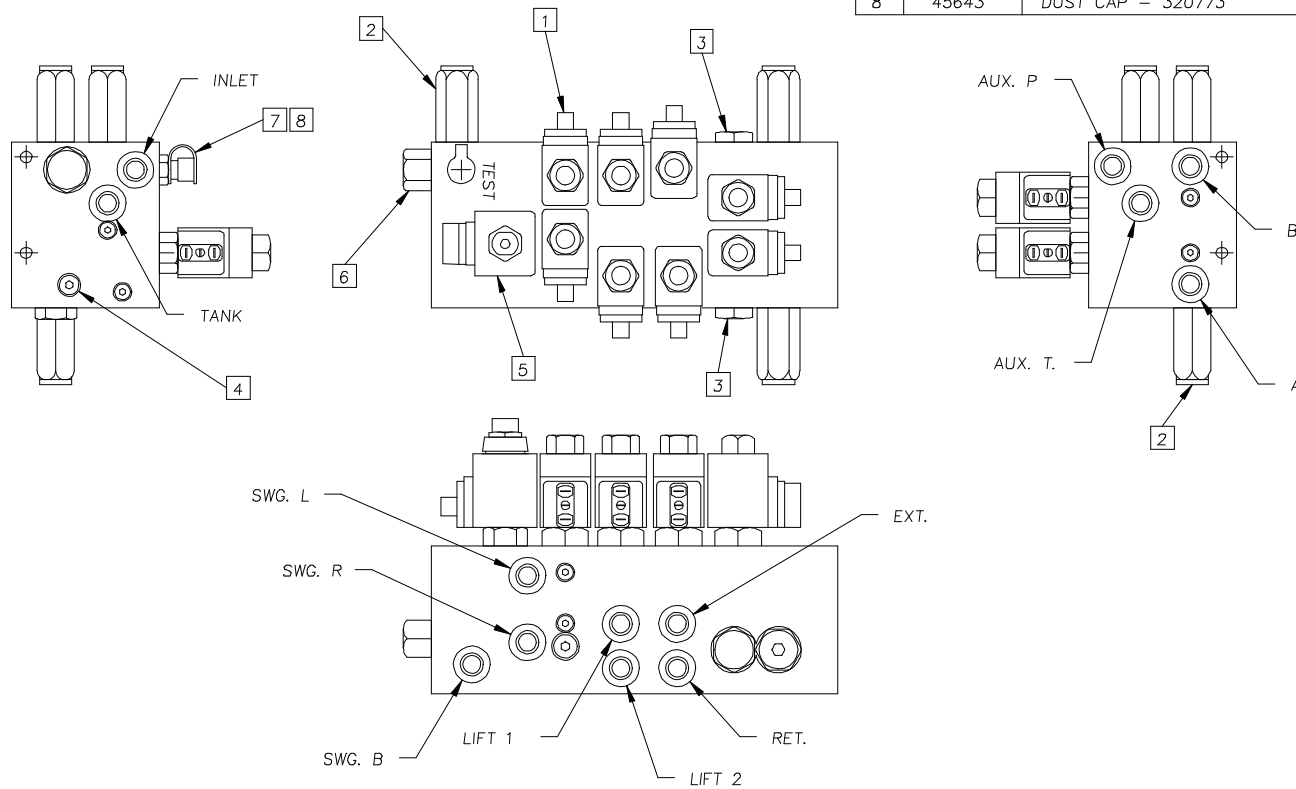

Z45/22 DC
 DRIVE FUNCTION MANIFOLD
 SERIAL # 4588-1550 & ABOVE

1	45479	2 POSITION-3 WAY SOLENOID / CP521-2-B-0-20D-S	4
2	45480	FLOW DIVIDER / CP341-1-B-0-1010	1
3	45481	CHECK VALVE / CP100-1-B-0-005	2
4	45482	RELIEF VALVE / CP200-2-B-0-A-C-150	2
5	45483	MINI SHUTTLE VALVE / 920067	1
6	45484	N.C. PROPORTIONAL SOLENOID / CP551-30-B-0-10G-24D-S	1
7	45485	RELIEF VALVE / CP200-1-B-0-A-B-075	1
8	45486	DO1 VALVE / CPD01C-1-V-1-20D-S	1
9	45487	DIFF. SENSING VALVE / CP700-2-B-0-100	1
10	45488	FLOW REGULATOR 920456	1
11	45779	RELIEF VALVE / CP200-1-B-0-A-C-350	1
12	45642	DIAGNOSTIC NIPPLE - 320772	1
13	45643	DUST CAP - 320773	1

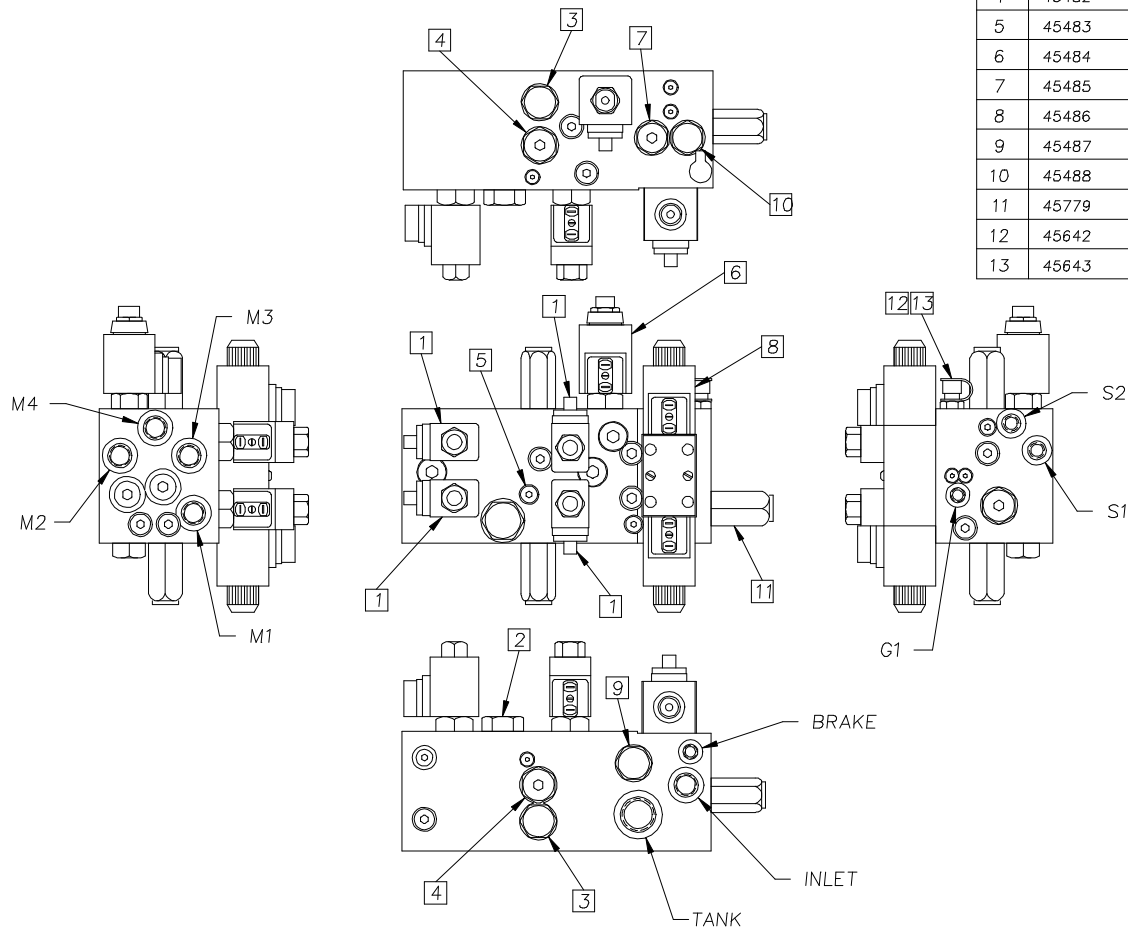

Z45/22 MP DC
HYDRAULIC SCHEMATIC

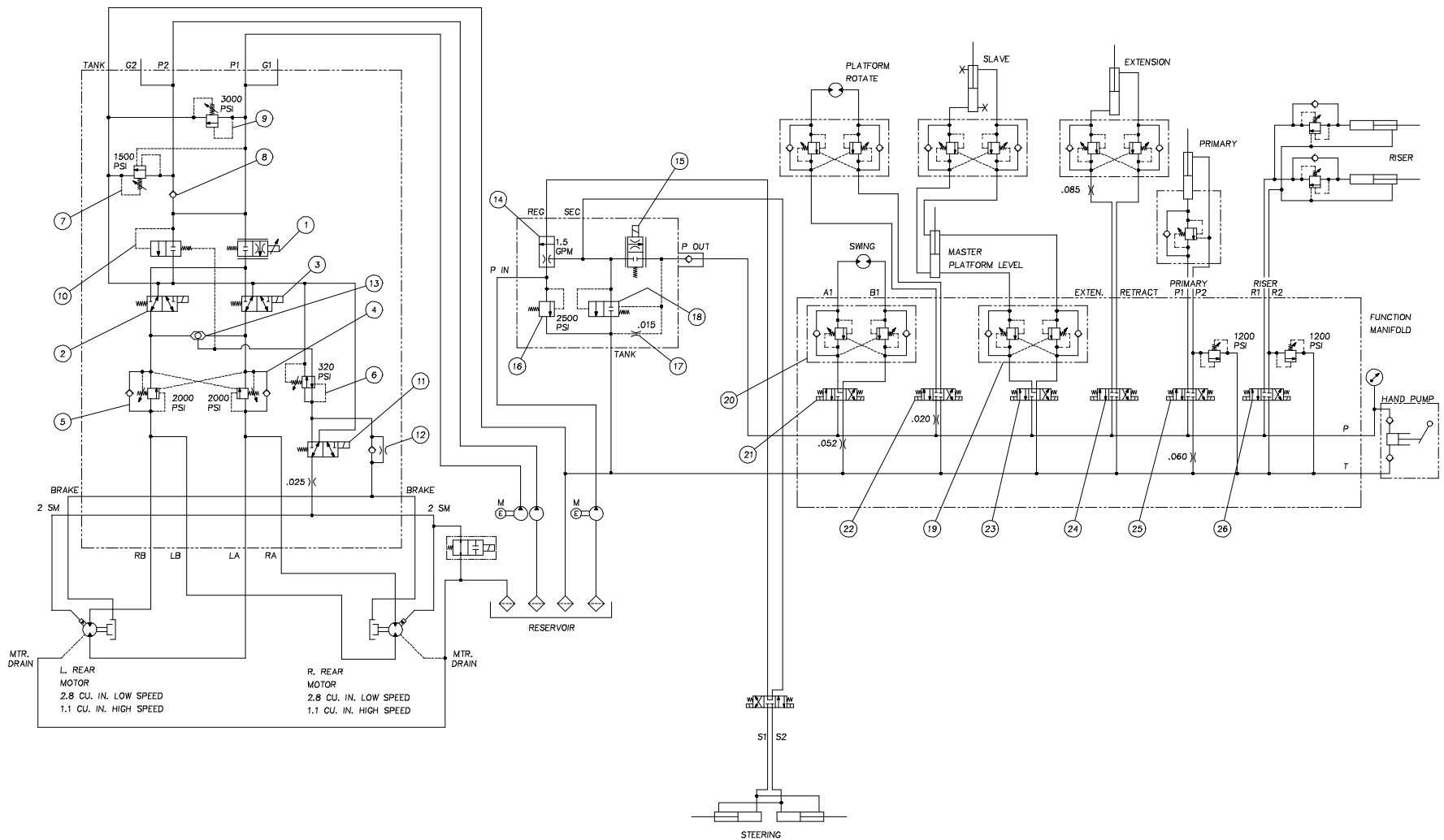

Z45/22 MP DC
HYDRAULIC SCHEMATIC LEGEND

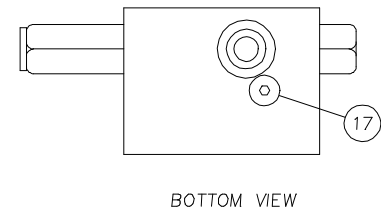
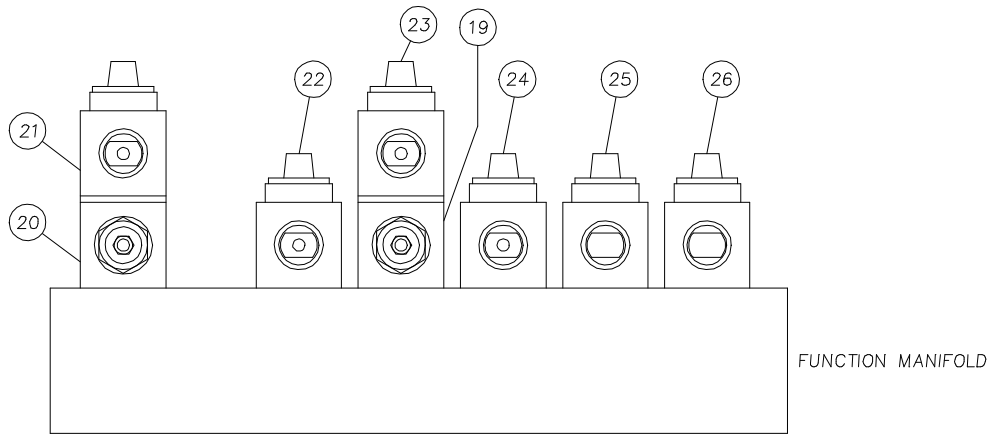
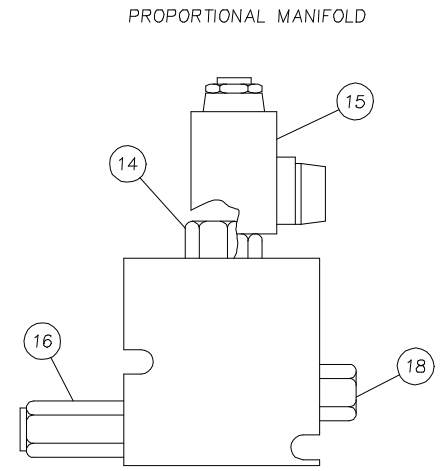
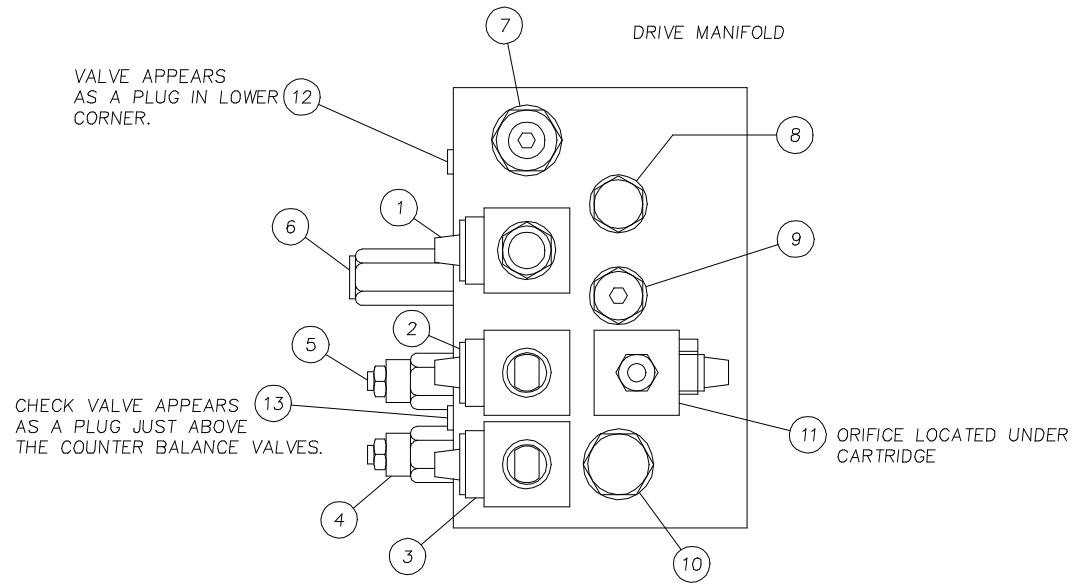

Z45/22 DC 2WD
 HYDRAULIC SCHEMATIC
 SERIAL #Z45-4916 & ABOVE

