

Kao Fong / Sharp / Jet / Ko Shin / Warco
Milling Machine Manual
Model # KF V0-A2F

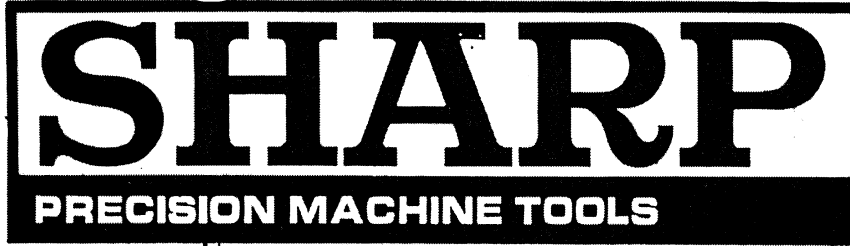

**TURRET MILLING
MACHINE**

SHARP (KFM
KFP

SERVICE MANUAL

READ THIS MANUAL CAREFULLY

It is essential to give the Serial Number of your machine in any order of repair parts to assure prompt and accurate service.

Order repair parts by part numbers, description and machine serial number.

13132 S. WESTERN AVE. • GARDENA, CA. 90249
TELEX: 674576 FULLONG
PHONE: (213) 327-0005 • 327-0122

SPECIFICATIONS

TABLE

Working surface.....	7" × 30"
T-slot number.....	3
T-slot size.....	$\frac{9}{16}$ "
RANGE	
Longitudinal (manual).....	21"
Longitudinal (power).....	17½"
Cross.....	7½"
Vertical.....	13¾"
Ram.....	7" (5" Dia.)
*POWER FEEDS	
Longitudinal (in./min.).....	$\frac{1}{16}$ - 12 $\frac{1}{16}$
Rapid travel (in./min.).....	63 $\frac{3}{4}$
SPINDLE	
Spindle travel.....	3 $\frac{1}{4}$ "
Spindle type.....	R-8
Speeds (10).....	190 - 3200 RPM
Max. distance from table.....	14"
Distance from column.....	14"
Vertical tilt (R & L).....	90°
Turret swivel.....	360°
MOTOR	
Vertical spindle.....	1/0.5 HP
* Power feed.....	$\frac{1}{4}$ HP
NET WEIGHT	1,200 lbs.
OVERALL HEIGHT	63"

DIMENSION DRAWING

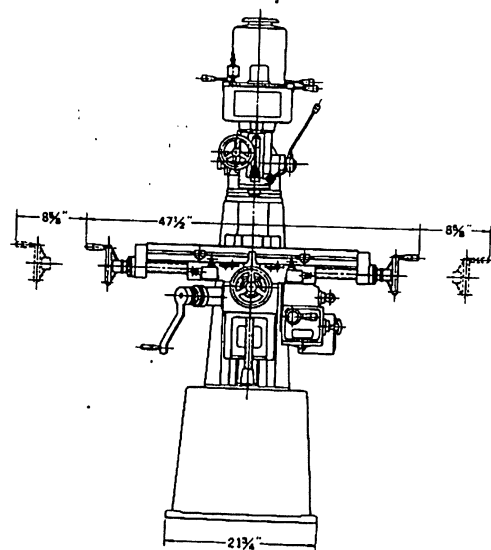
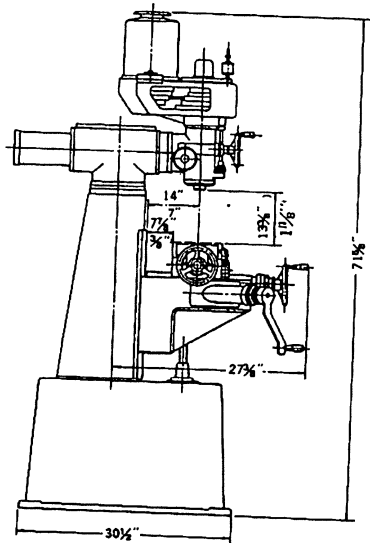

FEATURES

1. The model KF-VO-A2F milling machine is a newly developed product, it was designed to suit the needs of technical training schools, research departments, production shops, and manufacturers of tools and dies.
2. The machine is ideally suited for conventional milling, dies, drilling and jig boring.
3. The castings are fine grained cast iron with high tensile strength and closely controlled metallurgical content. After natural ageing, the castings are annealed and furnace tempered to minimize subsequent deformation.
4. All bearing surfaces are machined on modern numerically controlled machines to ensure that uniformity and interchangeability. Then, the ways are hand scraped to provide accurate alignments and optimize lubrication effectiveness.
5. The Acme leadscrews are precision machined on a thread mill. The radial and axial critical pitch tolerances are controlled to minimize backlash.
6. The massive round ram can be infinitely adjusted to the most practical position for the work to be accomplished. The key assures consistent vertical alignment. For angular milling, the head may be swiveled and firmly secured in place by three bolts.
7. The vertical head is designed so that vibration free, quiet performance is assured. The design facilitates uniform transfer of heat. A spindle brake can be supplied as optional equipment.
8. Automatic table feed (optional) provides ten wide range power feeds and rapid traverse by finger-tip control at the feed/rapid traverse control lever. The two limit switches can be set at desired locations to automatically interrupt feed at either end of the table travel.

PREPARATION

1. Remove the protective crating and skids carefully. In the event of damage in transit, notify the carrier promptly and inform your dealer.
2. This machine has been subjected to the KAO FENG Tri-phase quality control system. Tolerance and operational tests are conducted under work simulating conditions. If any defects or irregularities are discovered, please notify your dealer.
3. Please read the catalog and manual carefully to become familiar with the function of this machine. The operator should be thoroughly familiar with all functions before the machine is placed into operation.

INSTALLATION

1. Set the machine on a solid concrete foundation. It is advisable to apply some "grout" to eliminate any irregularities in the concrete. This will ensure a solid foundation at all points. If the foundation is not stable, a concrete slab should be poured to accommodate the machine.

INITIAL LUBRICATION

1. Thoroughly clean the machine with a solvent which is safe to handle and which will not affect the machines painted surfaces. Lubricate always with SAE10 and gears with SAE30 lubricant. Be certain that the machine is thoroughly lubricated before starting.

LEVELING

1. Thoroughly clean the table surface. Using a precision machinist level alternately in the longitudinal and transverse positions, level the machine by use of leveling screws. If the machine is not perfectly level in both directions, it is possible that tolerances will be affected and machine movements may not be free. The machine should be periodically checked for level to ensure long life.

ELECTRICAL SOURCE

1. The control panel and illuminating lamp are located on the left side of the column. Check the motor specifications to be sure that the electrical source is proper. The spindle switch is located on the left side of the motor.

FEED STOPS

1. The longitudinal and cross feed can be set for any travel distance required by adjusting and setting the stops located on the front of the table and on the right side of knee.

ADJUSTMENT OF GIB

1. The table is provided with a full length, hand scraped, tapered gib on the front side of the saddle. There is an adjusting screw at each end. To adjust the gib, tighten the two screws until a slight drag is felt when moving the machine by hand. If the table is not tight enough, loosen the adjusting screw on the small end of the gib and tighten the other end. If the feel is too tight, reverse the procedure.

ADJUSTMENT OF SADDLE AND KNEE GIBS

1. To properly adjust the feel of the cross movement and the vertical movement, follow the same procedure as described above.

TABLE, SADDLE AND KNEE CLAMPS

1. When milling with longitudinal feed, it is advisable to clamp the knee and saddle rigidly to permit heavy cuts with a minimum of vibration. The saddle clamp is located on the left side of the machine. The knee clamp is located at the left of the knee. Leave this clamp locked at all times unless the knee is being moved.

REMOVING TABLE

1. The table may be prepared for removal by: removing handwheel, dial holder, bearing bracket and then turning the leadscrew to its extremity so that the table can be removed. This will permit easily disassembling the table from the machine.

REMOVING SADDLE

1. Remove handwheel, dial holder, bearing bracket. Then, loosen set screw on the middle of the saddle. Remove hexagon socket screws from gear box (on machines with power feed). Take off gear box, fixed pin, upper cover and withdraw saddle gib. The saddle can then be removed.

CHANGING SPINDLE SPEEDS

1. Loosen the two locking bolts on the sides of the motor. Pull back the tension lever.
2. Move the belt to the desired groove.
3. Set belt tension and lock the two locking bolts.

REMOVING MOTOR

1. proceed to loosen belt according to above instructions.
2. Take off the motor and one of the pulleys.
3. Loosen the 8 hexagon socket screws in the upper cover of the belt housing. Lock uniformly the 3 small hexagon socket screws and take off belt housing cover.
4. Loosen the 4 hexagon socket screws and take off aluminum cover.

QUILL LOCK AND QUILL FEED

1. The handle at the right lower corner of the head is the quill lock. When the vertical feed is not being used, clamp the quill lock so that maximum rigidity is assured.
2. The vertical oil cup is located in the upper side of the belt housing. Oil should be applied 2 or 3 times each day to maintain the spindle lubrication.
3. The graduated micrometer depth stop facilitates working to accurate depths. The lock nut under the micrometer nut locks the micrometer nut securely in position.
4. The feed lever on the right side of the machine provides sensitive feed for milling or drilling. To engage the fine worm feed, turn the knurled clutch nut by hand (clockwise) until the fine feed handwheel is engaged. This will permit very fine feeding for boring operations or for heavy drilling. To disengage the worm feed, turn the clutch lock nut counterclockwise.

SPEED CHANGE GEAR BOX

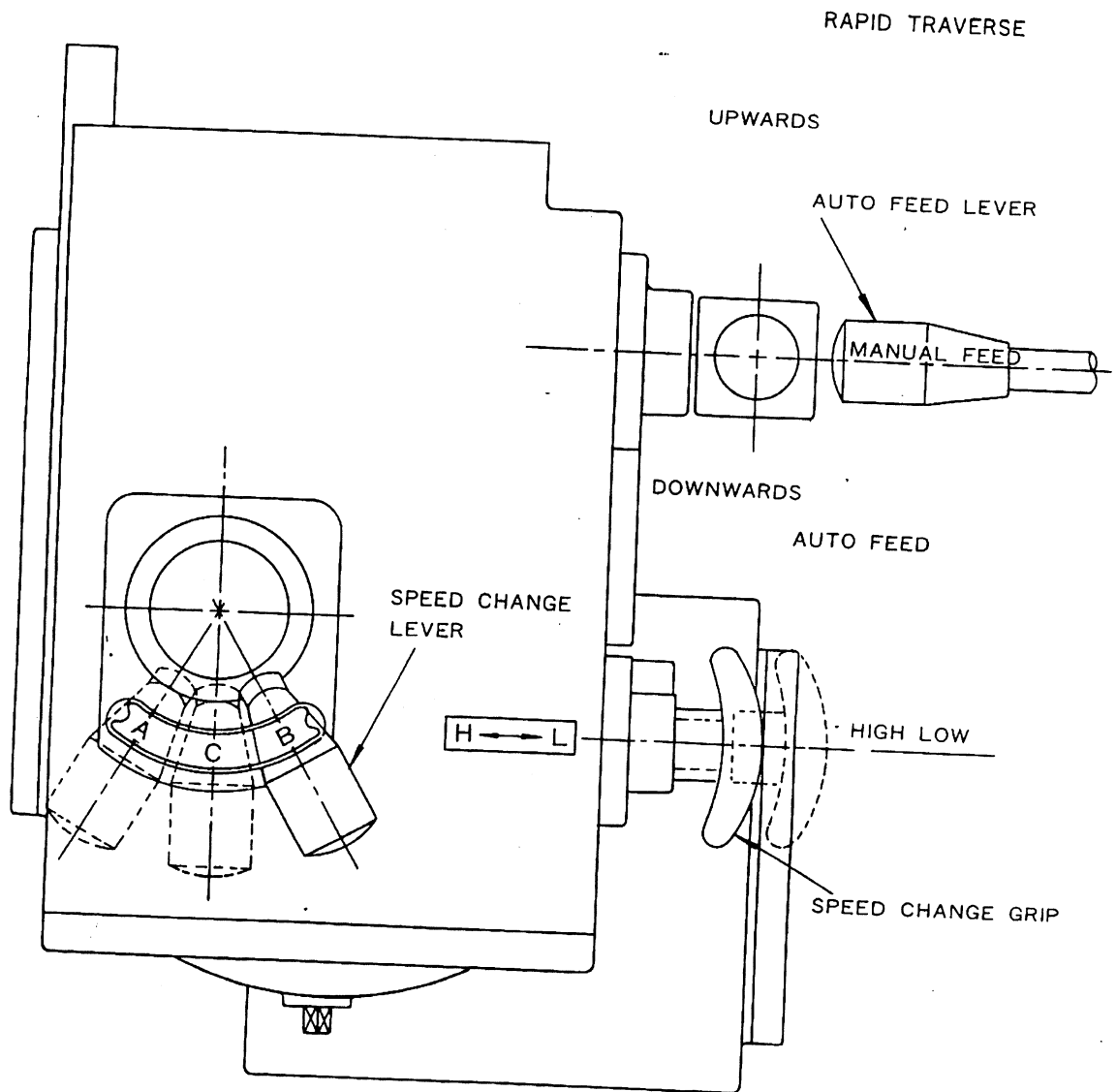

KF-VO-A2

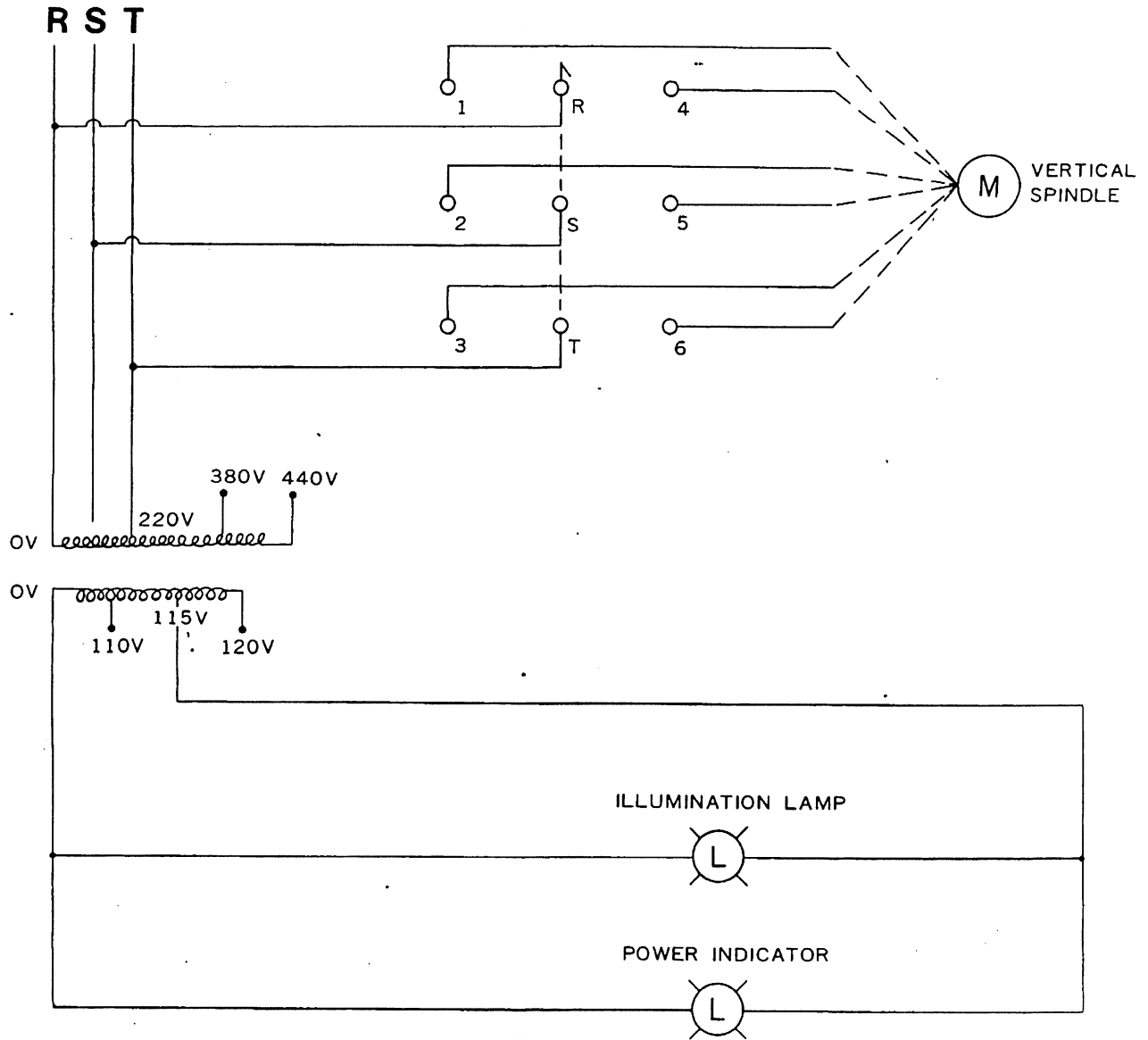

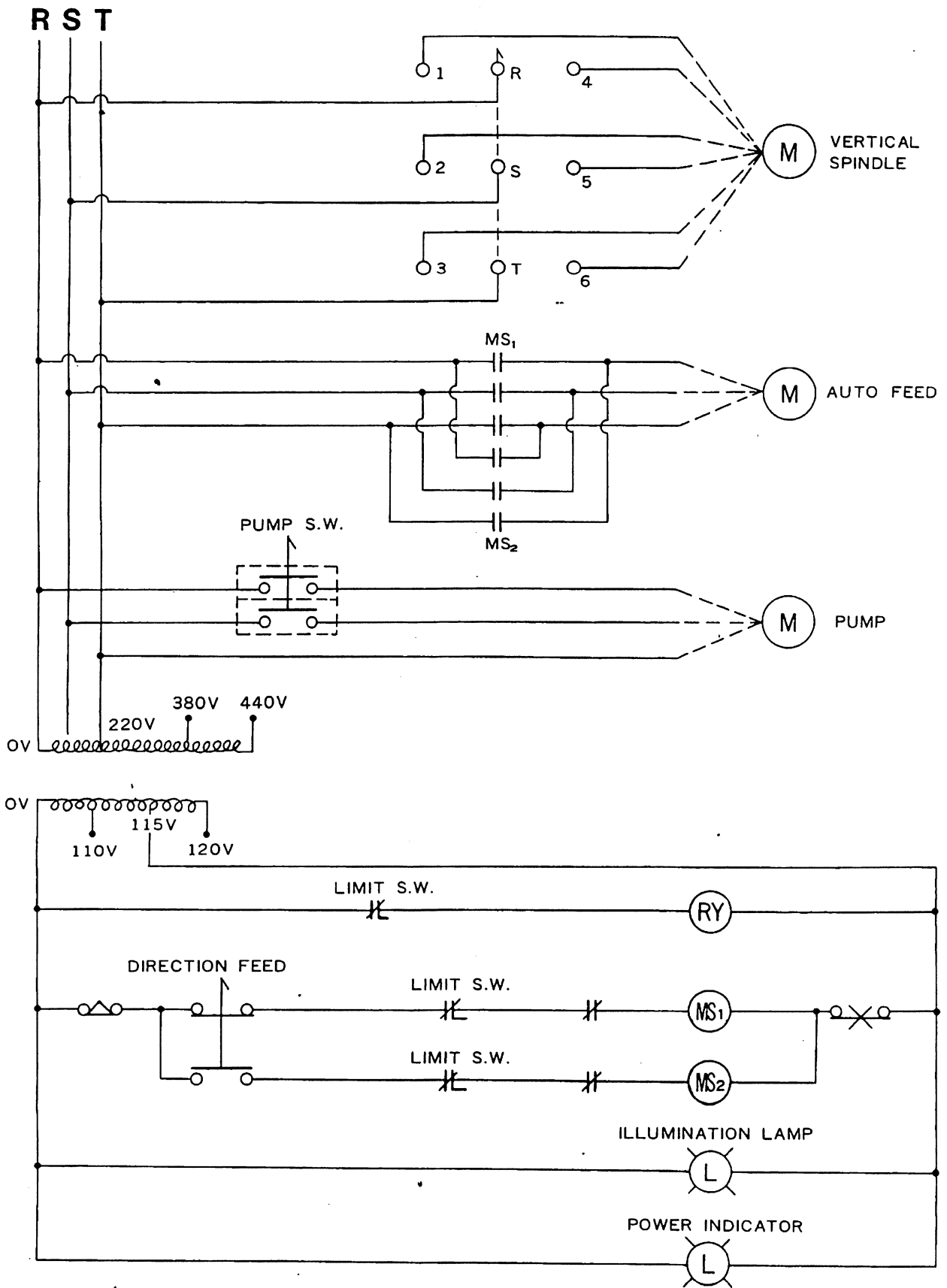

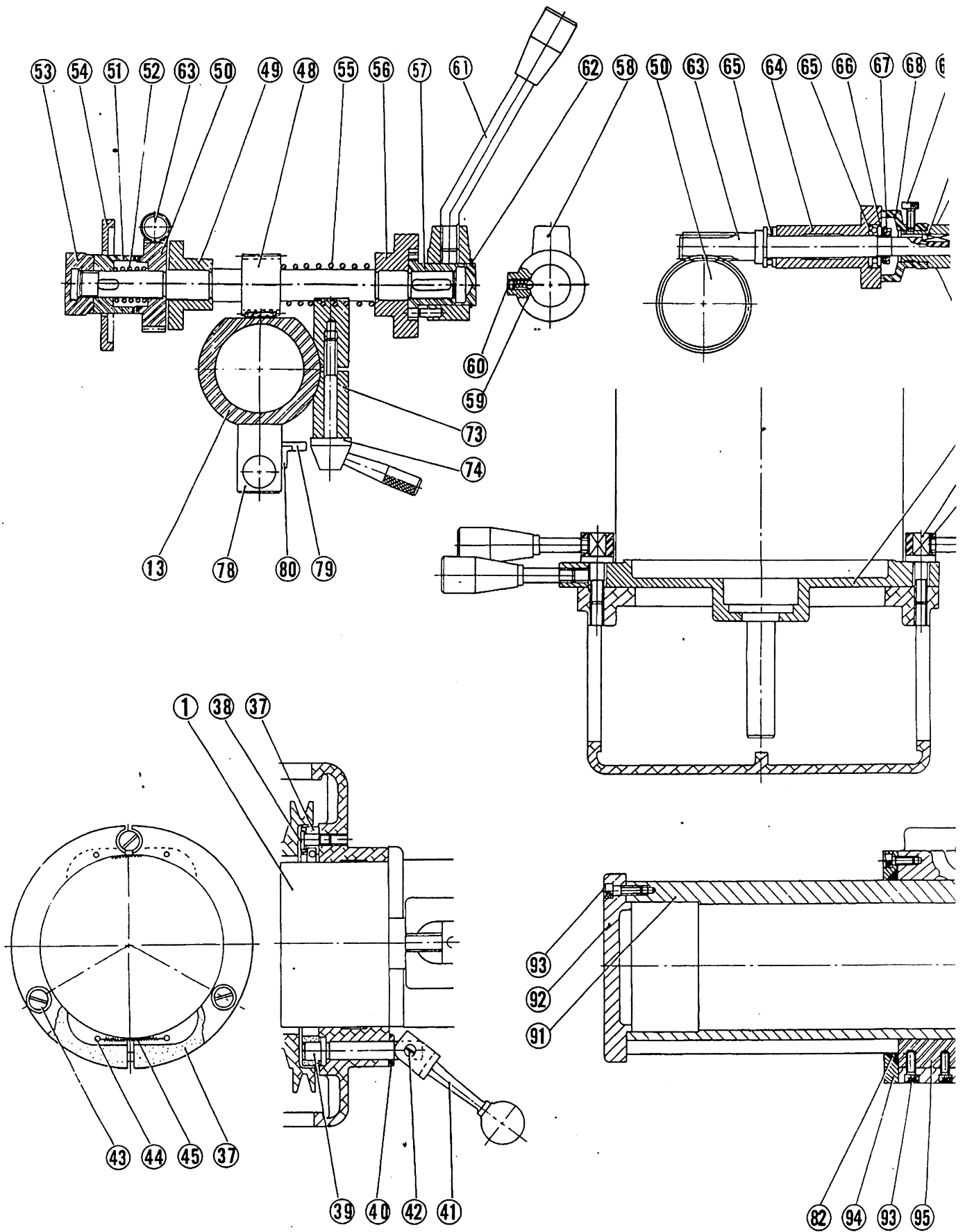

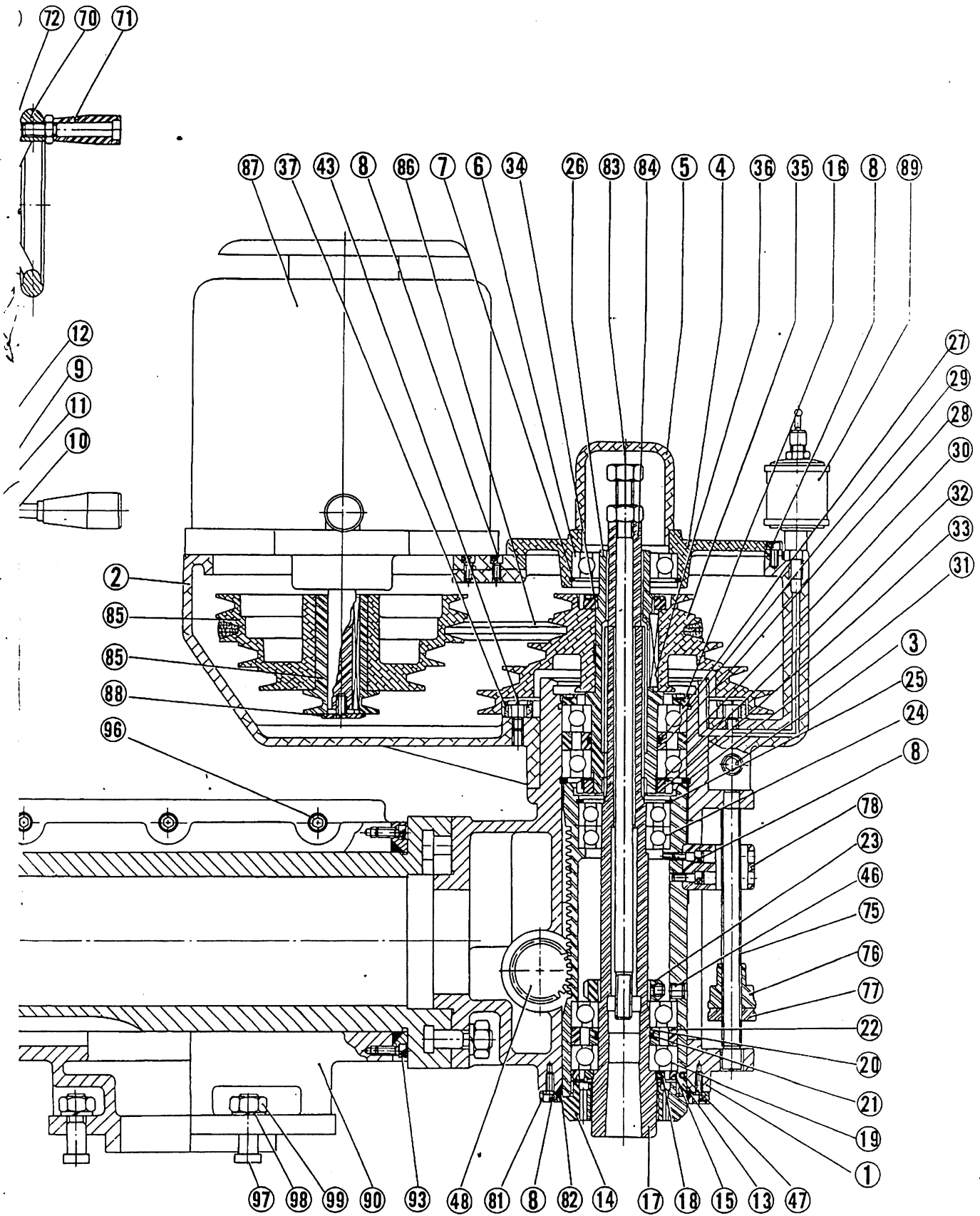

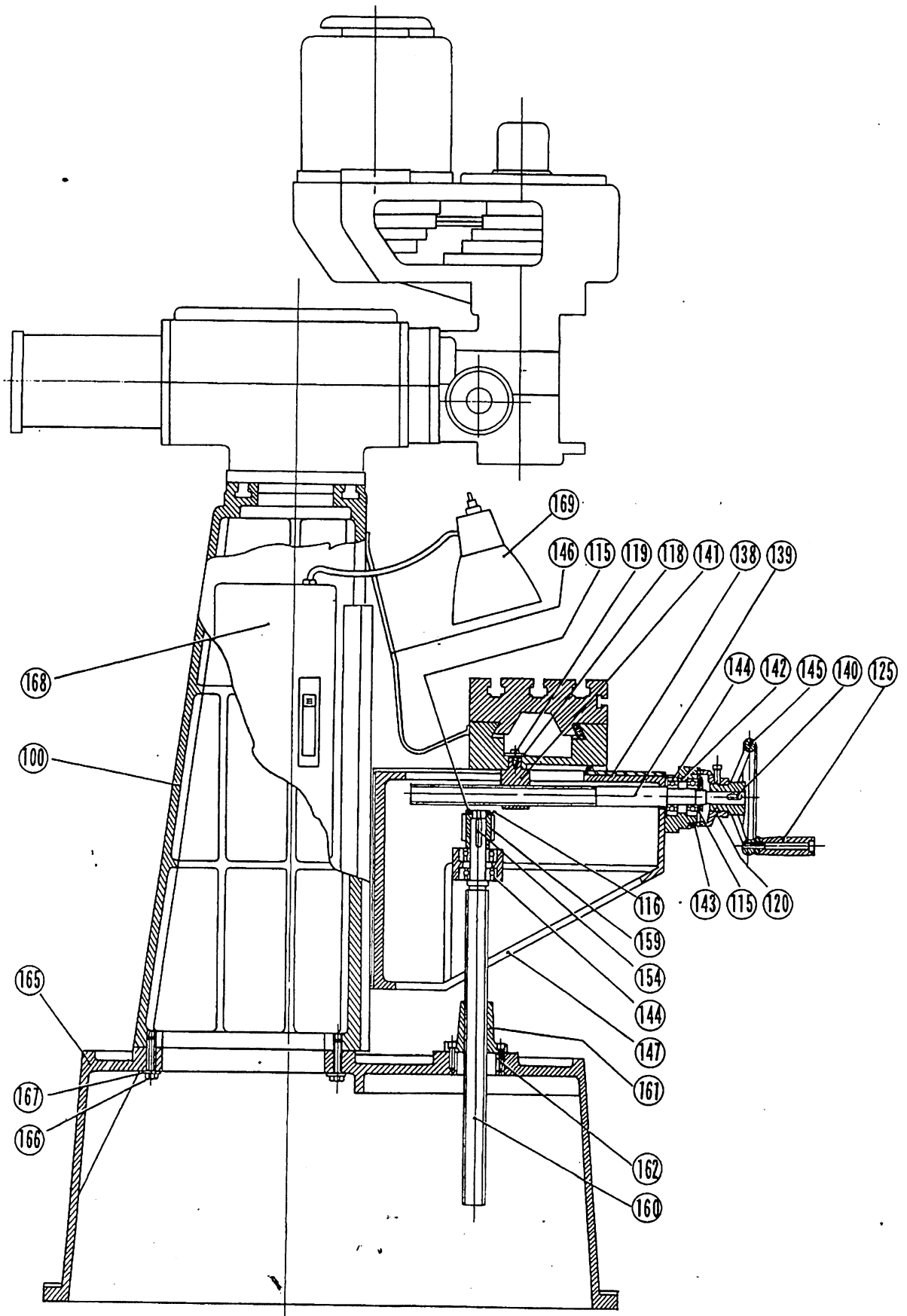

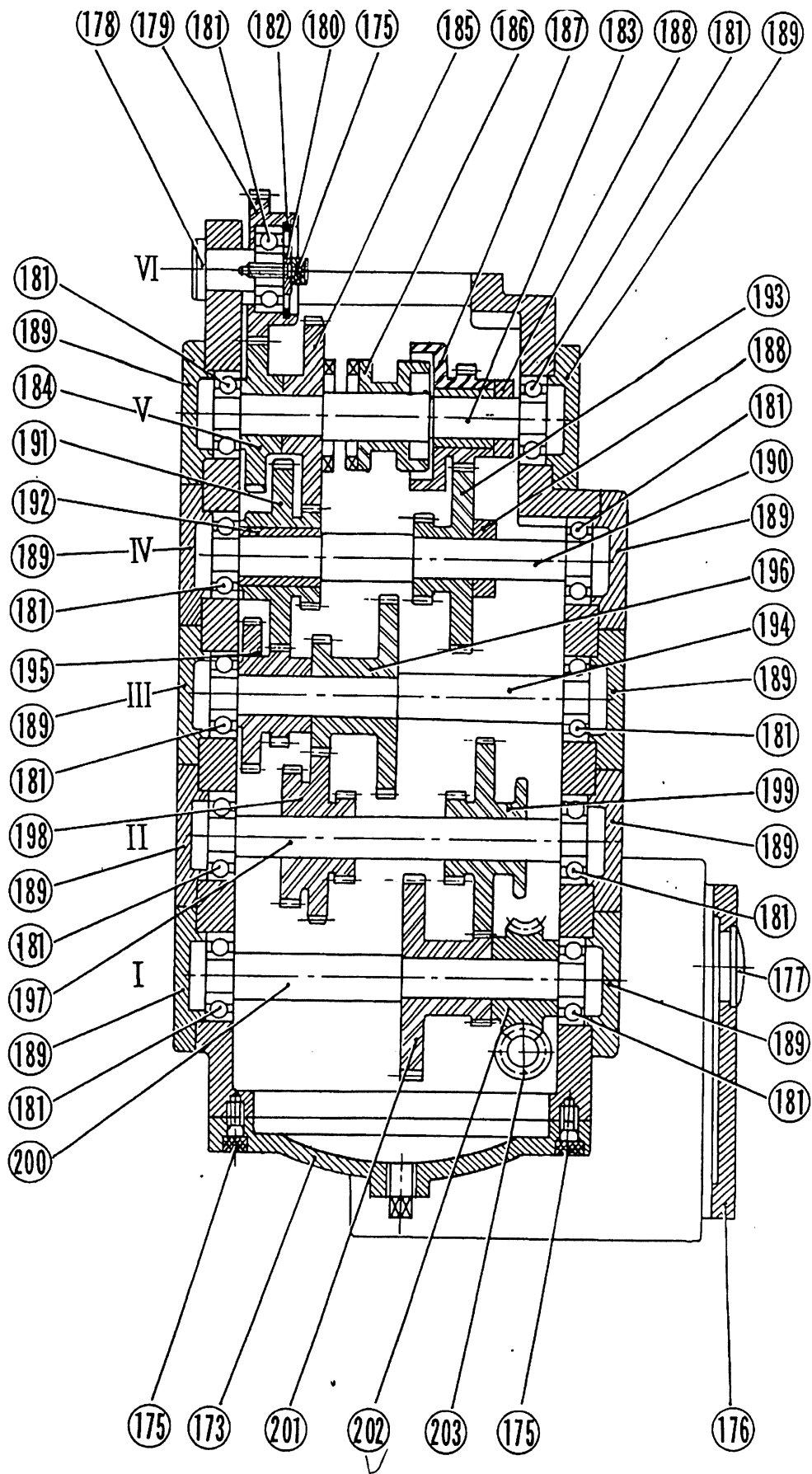

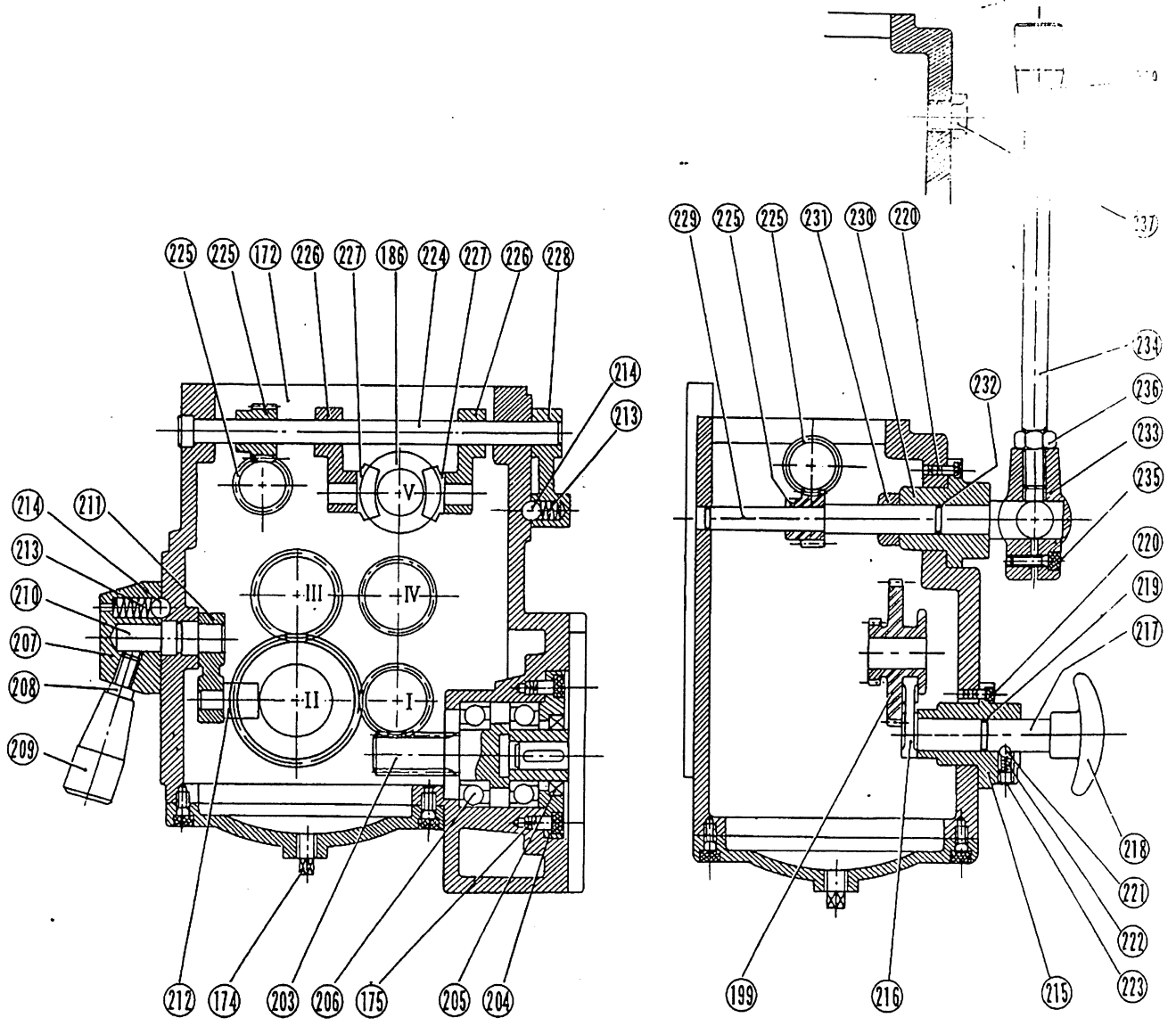

S/N	P/N	DESCRIPTION	S/N	P/N	DESCRIPTION
1	A2H-1	Vertical milling head	41	A2H-28	Brake bar
2	A2H-2	Belt housing	42	A2H-29	Set shaft
3	$\frac{3}{8}$ "x32 ℓ	Screw	43	A2H-30	Locking screw
4	A2H-3	Bearing seat	44	STD	Spring pin
5	A2H-4	Draw bar cover	45	STD	Spring
6	6207ZZ	Bearing	46	M10x10 ℓ	Set screw
7	H-72	Snap ring	47	M4x4 ℓ	Set screw
8	M5x15 ℓ	Screw	48	A2H-31	Quill pinion shaft
9	A2H-5	Motor set screw	49	A2H-32	Pinion shaft seat
10	A2H-6	Handle	50	A2H-33	Clutch worm gear
11	A2H-7	Square socket	51	A2H-34	Clutch
12	A2H-8	Motor mounting	52	STD	Spring
13	A2H-9	Quill	53	A2H-35	Clutch adjusting nut
14	A2H-10	Locking nut	54	A2H-36	Clutch cover
15	A2H-11	Spindle bearing locking nut	55	STD	Spring
16	A2H-12	Bearing locking nut	56	A2H-37	Pinion shaft seat
17	A2H-13	Vertical spindle	57	A2H-38	Pinion shaft sleeve
18	A2H-14	Spindle oil seal	58	A2H-39	Hand bar holder seat
19	7207CA	Bearing	59	$\varnothing 5$	Steel ball
20	A2H-15	Collar	60	M6x6	Set screw
21	G-35	O ring	61	A2H-40	Hand bar
22	A2H-16	Collar	62	E-19	Snap ring
23	A2H-17	Bearing adjusting nut	63	A2H-41	Fine feed worm shaft
24	6206	Bearing	64	A2H-42	Worm shaft sleeve
25	H-62	Snap ring	65	51102	Thrust bearing
26	A2H-18	Spindle transmission sleeve	66	AW 02	Washer for bearing
27	6209	Bearing	67	A2H-43	Thrust locking nut
28	A2H-19	Collar	68	A2H-44	Dial
29	G-45	O ring	69	A2H-45	Dial positioning screw
30	A2H-20	Collar	70	A2H-46	Hand wheel
31	H-85	Snap ring	71	A2H-47	Hand bar sleeve
32	STD	Washer for bearing	72	5x5x22	Key
33	A2H-21	Nut for bearing	73	A2H-48	Quill locking block
34	A2H-22	Pulley locking nut	74	A2H-49	Quill locking bolt
35	A2H-23	Spindle pulley	75	A2H-50	Quill stop micro screw
36	7x7x49	Key	76	A2H-51	Micro meter nut
37	A2H-24	Brake block	77	A2H-52	Quill micro stop nut
38	A2H-25	Locking screw	78	A2H-53	Quill stopper
39	A2H-26	Brake lock stud	79	A2H-54	Micro meter scale
40	A2H-27	Washer	80	A2H-55	Micro meter pointer

S/N	P/N	DESCRIPTION	S/N	P/N	DESCRIPTION
81	A2H-56	Felt ring	121	A2T-16	Dial positioning screw
82	STD	Felt	122	A2T-17	Hand wheel clutch
83	A2H-57	Draw bar	123	A2T-18	Hand wheel clutch
84	A2H-58	Draw bar sleeve	124	A2T-19	Hand wheel
85	A2H-59	Motor pulley	125	A2T-20	Hand bar sleeve & bolt
86	A-31	Vee belt	126	5x5x27	Key
87	0.35KW 8P 0.70KW 4P	Motor	127	S-16	Snap-ring
88	A2H-60	Washer	128	A2T-21	Stopper
89	STD	Oiling cup	129	A2T-22	Longitudinal travel adjusting screw
90	A2H-61	Vertical head adapter			
91	A2H-62	Ram	130	A2T-23	Longitudinal stop block
92	A2H-63	Tail cover	131	STD	Nut
93	M6x15	Screw	132	A2T-24	Table locking screw
94	A2H-64	Felt ring	133	A2T-25	Handle bar
95	19x19x50	Key	134	3/16"	Copper block
96	3/16"x32	Screw	135	STD	Grease nipple
97	A2H-65	Adapter set bolt	136	A2S-1	Saddle
98	STD	Spring washer	137	A2S-2	Saddle gib
99	STD	Nut	138	A2S-3	Chip guard
100	A2C-1	Column	139	A2S-4	Cross lead screw
101	A2T-1	Table	140	5x5x22	Key
102	A2T-2	Table gib	141	A2S-5	Cross feed nut
103	A2T-3	Gib adjusting screw	142	A2S-6	Cross feed bearing bracket
104	A2T-4	Dial support ring	143	A2S-7	Dial support ring
105	A2T-5	Longitudinal bearing bracket	144	6204	Bearing
106	6303	Bearing	145	A2S-8	Hand wheel
107	H-47	Snap ring	146	A2S-9	Chip guard
108	A2T-6	Longitudinal bearing bracket	147	A2K-1	Knee
109	7204	Bearing	148	A2K-2	Knee gib
110	A2T-7	Longitudinal lead screw	149	A2K-3	Knee locking screw
111	A2T-8	Longitudinal feed screw bushing	150	A2K-4	Handle bar
112	A2T-9	Longitudinal auto feed gear	151	A2K-5	Gear shaft sleeve
113	A2T-10	Gear setting cap	152	A2K-6	Gear shaft
114	A2T-11	Transmission gear locking nut	153	6x6x28	Key
115	A2T-12	Locking nut	154	5x5x40	Key
116	AW-04	Washer for bearing	155	A2K-7	Elevating sub-dial
117	A2T-13	Longitudinal feed nut	156	A2K-8	Elevating handle clutch
118	A2T-14	Washer	157	A2K-9	Handle arm
119	1/4"x3/4"	Screw	158	S-18	Snap ring
120	A2T-15	Dial	159	A2K-10	Elevating gear

S/N	P/N	DESCRIPTION	S/N	P/N	DESCRIPTION
160	A2K-11	Elevating lead screw	200	A2G-24	I Gear shaft
161	A2K-12	Elevating lead screw set nut	201	A2G-25	I Shaft transmission gear
162	¼"x1"	Screw	202	A2G-26	I Shaft worm gear
163	A2K-13	Chip guard	203	A2G-27	Motor transmission worm shaft
164	⅜"x¾"	Screw	204	A2G-28	Bearing setting cover
165	A2B-1	Base	205	TC25x40x8	Oil seal
166	⅞"x1½"	Screw	206	#7205	Bearing
167	STD	Spring washer	207	A2G-29	Hand bar adapter
168	STD	Switch	208	A2G-30	Hand bar
169	STD	Illumination	209	STD	Plastic handle
170	STD	Limit switch	210	A2G-31	Adapter pivot
171	STD	Oil cup	211	A2G-32	Shifting swivelling arm
172	A2G-1	Gear box	212	A2G-33	Shifting fork
173	A2G-2	Bottom cover	213	STD	Spring
174	⅜"	Oil drainage screw	214	D⅜"	Steel ball
175	M6x12 ℓ	Screw	215	A2G-34	High-low speed shaft holder
176	A2G-3	Oil indicator frame	216	A2G-35	Shifting sector arm
177	STD	Oil indicator	217	A2G-36	High-low speed shifting shaft
178	A2G-4	VI Gear shaft	218	A2G-37	Speed shifting knob
179	A2G-5	VI Shaft gear	219	P-16	O ring
180	A2G-6	VI Shaft washer	220	M5x10 ℓ	Screw
181	#6201	Bearing	221	D¼"	Steel ball
182	H-32	Snap ring	222	STD	Spring
183	A2G-7	V Gear shaft	223	M8x10 ℓ	Set screw
184	A2G-8	V Shaft transmission gear	224	A2G-38	Suspending beam
185	A2G-9	V Shaft low speed gear	225	A2G-39	Helical gear
186	A2G-10	High speed clutch	226	A2G-40	High-low speed swivelling arm
187	A2G-11	Clutch adapter	227	A2G-41	High-low speed shifting block
188	A2G-12	Gear setting ring	228	A2G-42	High-low lever positioning device
189	A2G-13	Gear shaft cover	229	A2G-43	Hi-low speed changing shaft
190	A2G-14	IV Gear shaft	230	A2G-44	Hi-low speed shaft holder
191	A2G-15	IV Shaft transmission gear	231	A2G-45	Hi-Low speed shaft positioning ring
192	A2G-16	Copper bushing	232	P-14	O ring
193	A2G-17	High speed transmission gear	233	A2G-46	Hand bar adapter
194	A2G-18	III Gear shaft	234	A2G-47	Hand bar
195	A2G-19	III Shaft small transmission gear	235	W¼"x¾" ℓ	Screw
196	A2G-20	III Shaft big transmission gear	236	W½"	Nut
197	A2G-21	II Gear shaft	237	STD	Filling oil bolt
198	A2G-22	II Shaft gear cluster			
199	A2G-23	II Shaft gear cluster			

Please find the serial number from drawings.
The part number and description will help with identification.