

Helical Gear Design

This is a treatise on how I calculate basic dimensions and angles in making helical or skew gears for model engines. I can't assure you that this information is exactly correct, but I the gears that I have made mate and work flawlessly, so I have to think it's pretty much right on.

Spur Gear Basics

I'll start with just the fundamentals of spur gears since most of the terms are the same for both helical and straight gears. Straight spur gears are, after all, helical gears with a 0 degree helix angle. I won't get in to gear tooth cutter design since I use commerical gear cutters and don't understand enough about tooth shapes to be schooling anyone. You can skip to the next section if you're already pretty familiar with straight spur gears.

Pitch Diameter – This is the diameter of a circle, called the pitch circle, as measured a little bit over half way between the tips and valleys of the gear teeth. When calculating the gear dimensions, you first calculate the pitch diameter. From there, you can calculate the outside diameter and finally, the depth of cut for each tooth.

Diametral Pitch – This describes the number of teeth in a gear with a 1" pitch diameter.

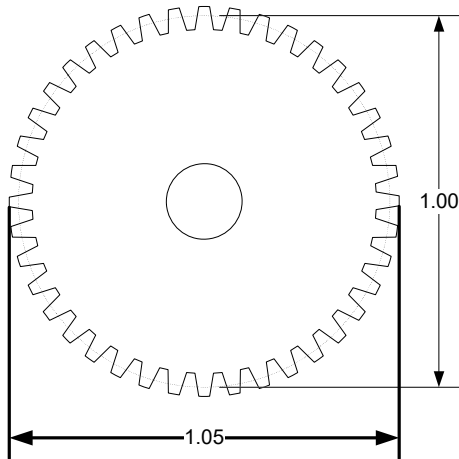

The circle with the dotted line in the gear to the left describes the pitch circle and its diameter is the pitch diameter, which is 1 inch. Since the gear has 40 teeth, this gear has a DP (diametral pitch) of 40.

The pitch diameter is determined by dividing the number of teeth in the gear you are designing by the diametral pitch. So a 60 tooth gear would be 1.5" ($60 / 40$). $PD = N / DP$.

The distance from the Pitch Circle to the tip of the gear tooth is $1 / \text{Diametral Pitch}$ or $1 / 40$ in this case. Therefore, the outside diameter of the gear is determined by adding $2 \times 1 / 40$ to the Pitch Diameter. So, in the example to the left, $OD = 1 + (2 \times 1 / 40) = 1.050$ inches.

Helical Gear Calculations

The Pitch Diameter of a helical gear is determined much the same as a spur gear:

$$PD = N / (DP * \text{Cos } A)$$

The difference is that the Diametral Pitch must be multiplied by the Cosine of helix angle, as measured from the axis of the gear. As the helix angle increases, the COS decreases so the corresponding Pitch Diameter gets larger. Here is a list of Cosines for angles from 10 degrees to 80 degrees:

$$\text{COS } 10 \text{ Deg} = 0.985$$

$$\text{COS } 20 \text{ Deg} = 0.940$$

$$\text{COS } 30 \text{ Deg} = 0.866$$

$$\text{COS } 40 \text{ Deg} = 0.766$$

$$\text{COS } 50 \text{ Deg} = 0.643$$

$$\text{COS } 60 \text{ Deg} = 0.500$$

$$\text{COS } 70 \text{ Deg} = 0.342$$

$$\text{COS } 80 \text{ Deg} = 0.174$$

Using the example from the previous page, a straight spur gear of Diametral Pitch 40 having 40 teeth has a Pitch Diameter of 1 inch. If you change the helix angle to 10 degrees, the Pitch Diameter = 40 (teeth) / (40 (Diametal Pitch) * .985 (Cos 10 Deg)). This yields a Pitch Diameter of 1.015. Changing the helix angle to 40 degrees, the forumula becomes 40 (teeth) / (40 (Diametral Pitch) * .766). This gives a pitch diameter of 1.305 inches. Here are the formulas with values for each of the helix angles listed above:

$$10 \text{ Deg: } 40 / (40 \times .985) = 1.015''$$

$$20 \text{ Deg: } 40 / (40 \times .940) = 1.064''$$

$$30 \text{ Deg: } 40 / (40 \times .866) = 1.155''$$

$$40 \text{ Deg: } 40 / (40 \times .766) = 1.305''$$

$$50 \text{ Deg: } 40 / (40 \times .643) = 1.556''$$

$$60 \text{ Deg: } 40 / (40 \times .600) = 2.000''$$

$$70 \text{ Deg: } 40 / (40 \times .342) = 2.924''$$

$$80 \text{ Deg: } 40 / (40 \times .174) = 5.759''$$

Each of the above examples yields the Pitch Diameter of the gear. In every case, the outside diameter of the gear (and the gear blank) is determined by adding $2 \times 1 / 40$ where 40 is the Diametral Pitch of the gear.

Cutting a Helical Gear

When cutting a helical gear, you need to know the axial distance to move the gear as you are cutting the tooth around the pitch circle. This is easier to understand if you imagine a right triangle which would be formed by unwrapping 1 gear tooth from the helical gear and laying it out flat.

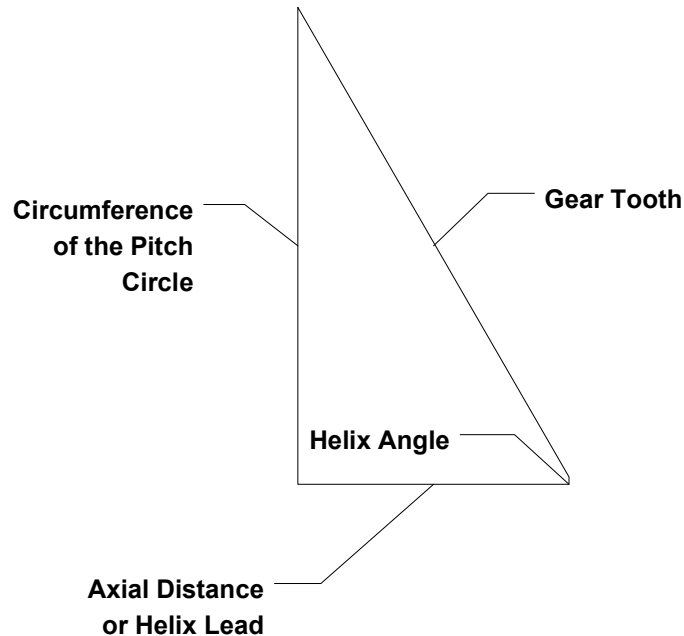

The left leg of the right triangle is the circumference on the Pitch Circle and is found by multiplying the Pitch Diameter by PI which is 3.14. The bottom leg of the triangle is the Helix Lead or the axial offset of the tooth for one full revolution of the gear. This distance can be calculated by dividing the Pitch Circle circumference by the Tangent of the Helix Angle.

Example: DP = 40, Helix Angle = 80 Deg, Number of Teeth = 6

$$\text{Pitch Diameter} = 6 / (40 * .174) = \mathbf{.862''}$$

$$\text{Circumference} = 0.862 * 3.14 = \mathbf{2.707''}$$

$$\text{Helix Lead} = 2.707 / 5.671 (\text{Tan } 80 \text{ Deg}) = \mathbf{0.477''}$$

So, when cutting a tooth, for each full revolution of the gear blank, the cutter must move .477" axially across the face of the gear blank.