

Boxford

Lathes

Parts List

Boxford Machine Tools Ltd., Wheatley,
Halifax, Yorkshire, England HX3 5AF.
Tel. 0422 58311/3. Telex 517410.
Grams. Boxford Halifax.



LATHE PARTS

- | | | | |
|------|--|-----|--|
| 1 | Bed (36", 42", 48"). | 31 | Apron Handwheel. |
| 3 | Headstock (Bench & Mk I Lathes). | 32 | Tailstock Handwheel. |
| 3TUD | Headstock (Training Lathe). | 33 | Idler Gear 80T. |
| 4 | Tailstock. | 34 | Large Gear 72T. } Compound. |
| 5 | Saddle. | 35 | Small Gear 18T. } |
| 6 | Cross Slide. | 36 | Change Gear 16T. |
| 7 | Compound Rest Slide. | 37 | Change Gear 24T. |
| 8 | Tool Slide. | 38 | Change Gear 32T. |
| 9 | Compound Rest Lead Screw (English). | 39 | Change Gear 36T. |
| 9M | Compound Rest Lead Screw (Metric). | 40 | Change Gear 40T. |
| 10 | Tool Slide Bush. | 41 | Change Gear 44T. |
| 11 | Dial (English). | 42 | Change Gear 46T. |
| 11D | Dial (English-Direct Reading). | 43 | Change Gear 48T. |
| 11M | Dial (Metric). | 44 | Change Gear 52T. |
| 11MD | Dial (Metric-Direct Reading). | 45 | Change Gear 54T. |
| 11V | Dial (Milling Attachment). | 46 | Change Gear 56T. |
| 11MV | Dial (Milling Attachment—metric). | 47 | Change Gear 60T. |
| 12 | Tool Slide Handle. | 49 | Change Gear 80T. |
| 13 | Locknut. | 50 | Tailstock Base. |
| 14 | Tool Slide Gib Strip. | 51 | Tailstock Lead Screw. |
| 15 | Tool Slide Nut (English). | 52 | Tailstock Spindle (English). |
| 15M | Tool Slide Nut (Metric). | 52M | Tailstock Spindle (Metric). |
| 16 | Clamp Slug. | 53 | Tailstock Stud. |
| 17 | Cross Slide Handle. | 54 | Tailstock Handle. |
| 18 | Cross Slide Bush. | 55 | Apron Cross Feed Gear 57T. |
| 19 | Cross Slide Nut (English). | 56 | Apron Cross Feed Gear 22T. |
| 19M | Cross Slide Nut (Metric). | 57 | Apron Idler Gear. |
| 20 | Cross Slide Dial (English). | 58 | Rack Pinion Gear. |
| 20M | Cross Slide Dial (Metric). | 59 | Apron Rack Pinion. |
| 21 | Cross Slide Gib Strip. | 60 | Apron Feed Pinion. |
| 21s | "T" Slot Cross Slide Gib Strip. | 61 | Apron ("A" & "B" Models). |
| 22A | Lead Screw (English "A" Model 36", 42", 48"). | 62 | Worm. |
| 22B | Lead Screw (English "B" Model 36", 42", 48"). | 63 | Worm Wheel. |
| 22MB | Lead Screw (Metric "B" Model 36", 42", 48"). | 64 | Apron Clutch Disc. |
| 22C | Lead Screw (English "C" Model 36", 42", 48"). | 65 | Apron Clutch Disc (inner). |
| 22MC | Lead Screw (Metric "C" Model 36", 42", 48"). | 66 | Apron Clutch Screw. |
| 23 | Split Nut Lever. | 67 | Apron Clutch Screw Pin. |
| 24A | Cross Slide Lead Screw (English "A" & "B" Models). | 68 | Worm Locknut. |
| 24MA | Cross Slide Lead Screw (Metric "A" & "B" Models). | 69 | Apron Clutch Knob. |
| 24C | Cross Slide Lead Screw (English "C" Model). | 70 | Retaining Screw. |
| 24MC | Cross Slide Lead Screw (Metric "C" Model). | 71 | Split Nut Pin. |
| 25 | Split Nut (Top Half—English). | 72 | Split Nut Lever Pin. |
| 25M | Split Nut (Top Half—Metric). | 73 | Rack Pinion Stud. |
| 26 | Split Nut (Bottom Half—English). | 74 | Idler Gear Shifter. |
| 26M | Split Nut (Bottom Half—Metric). | 75 | Gear Shifter Lever. |
| 27 | Saddle Gib. | 76 | Gear Shifter Knob. |
| 28 | Tailstock Clamp. | 77 | Gear Shifter Knob Plunger. |
| 29 | Apron Handwheel Pinion. | 78 | Auto Cross Feed Stud. |
| 30 | Half Nut Pivot. | 79 | Apron Worm Cover. |
| | | 80 | Idler Gear Shifter Lever. |
| | | 82 | Change Gear Quadrant. |
| | | 83 | Tailstock Bush. |
| | | 84 | Lead Screw Bracket (Front—"B" & "C" Models). |
| | | 85 | Lead Screw Bracket (Rear). |
| | | 86 | Headstock Clamp. |
| | | 88 | Washer. |
| | | 89 | Reverse Gear Stud. |
| | | 90 | Reverse Gear (Steel—14½° P.A.) |
| | | 90A | Reverse Gear (Steel—20° P.A.) |
| | | 90T | Reverse Gear (Fibre—14½° P.A.) |

- 90TA** Reverse Gear (Fibre—20° P.A.)
91 Reverse Gear follower (14½° P.A.)
91A Reverse Gear follower (20° P.A.)
92 Stud Gear Spindle.
93 Rack (For 36", 42" or 48").
94 Back Gear Handle.
95 Tailstock Nut.
96 Pad.
97 Retaining Pin.
98 Stop Pin.
99 Thread Indicator Body.
101 Plain Apron ("C" Model).
101P Plain Apron (Training Lathe).
102 Front Cover Plate.
103 Rear Cover Plate.
104 Large Back Gear.
105 Back Gear Sleeve.
106 Spindle Fixed Gear.
107 Spindle Sliding Gear.
108 Gear Shifter Eccentric.
109 Shoe.
110 Cover Bracket.
111 Indicator Worm Wheel.
112 Thread Indicator Shaft.
113 Thread Indicator Dial.
115 Main Spindle.
116 Eccentric Bush.
117 Spacing Washer.
117s Spacing Washer (Training Lathe).
118 Thrower.
119 Locknut.
120 Spacing Washer.
122 Nose Cap.
123 Catch Plate.
124 Sleeve.
125 Tailstock Centre.
126 Headstock Centre.
127 Tool Post.
128 Tool Post Block.
129 Tool Post Ring.
130 Tool Post Screw.
131 Tool Post Wedge.
132 Guard Fastening Piece.
133 Guard Thumb Screw.
134 Change Gear Guard.
140 Saddle Clamp.
141 End Plate.
142 Motor Platform.
144 Spindle End Cover.
145 Spacing Washer.
147 Guard Extension.
148 Spindle Locking Key.
149 Countershaft Drive Pulley.
150 Motor Pulley.
151 Pin (Compound Gears).
152 Bolt.
153 Eccentric Bush.
154 Change Gear Bush.
155 Taper Point Grub Screw.
156 Clamp Slug.
157 Cabinet (Pre-June 1957).
158 Cabinet Base.
160 Indicator Pin.
161 Standard Switch.
163 Guard Pin.
164 Back Gear Shaft.
165 Fixed Gear Pin.
166 Spacing Washer.
167 Gear Spacing Washer.
168 Screwcutting Chart (B & C Models).
169 Tailstock Button Key.
170 Motor Bracket Support.
171 Scroll.
173 Oil Feed Tube.
184 Face Plate.
185 Felt Washer (Front).
186 Felt Washer (Rear).
187 Felt Holder.
189 Wiper.
194 Oil Dipper.
195 Gear Retaining Spring.
196 Headstock Drive Pin.
197 "Boxford" Nameplate.
198 Pin (Main Spindle Key).
201 Gear Shifter Spring.
202 Guard Piece ("A" Model).
203 Guard Piece ("B" & "C" Models).
204 Retaining Spring.
205 Back Gear Spring.
206 Spindle Pulley Pin.
207 Back Gear Retaining Plate.
208 Back Gear Retaining Screw.
212 Special Grub Screw.
213 Change Gear 20T.
214 Change Gear 127T.
215 Change Gear 100T. } Compound.
216 Change Gear 100T.
217 Pin.
218 Change Gear 18T.
219 Change Gear 22T.
220 Change Gear 26T.
221 Change Gear 28T.
222 Guard Plate.
223 Guard Plate Pin.
224A Gib Strip Pin.
224B Gib Strip Pin.
225 Cross Feed Stud Spring.
226 Countershaft Upright.
227 Loose Bearing.
228 Retaining Washer.
229 Countershaft Spindle.
230 Main Spindle Key.
231 Stud Gear Spindle Key.
232 Lead Screw Key.
233 Worm Key.
234 Worm Locknut Pin.
235 Compression Spring.
236 Compression Spring.
241 Clip for Motor Lead.
242 Pin (Back Gear Shaft).
243 Pin (Back Gear Sleeve).
244 Pin (Belt Tension Screw).
245 Dowel.
247 Tailstock Offset Screw.
250 Spindle Pulley.
251 Countershaft Pulley.
252 Headstock Foot.
253 Tailstock Foot.
254 Support Spacer.
257 Belt-Tensioning Bush.

- 258 Belt Tensioning Screw.
 259 Belt Tensioning Screw Head.
 264 Oil Feed Tube.
 268 Change Gear 50T.
 276 Rack Washer.
 277 Headstock Speed Chart.
 278 "Boxford Machine Tools" Nameplate
 279 Screwcutting Chart (Metric "B"
 and "C" Models).
 280 Gear Box Body (English).
 280M Gear Box Body (Metric).
 281 L.H. Gear Box Lever.
 282 R.H. Gear Box Lever (English).
 282M R.H. Gear Box Lever (Metric).
 283 Gear 18T.
 284 Gear 20T.
 285 Gear 22T.
 286 Gear 23T.
 287 Gear 24T.
 288 Gear 26T.
 289 Gear 28T.
 290 Gear 16T. } Compound.
 291 Gear 32T. }
 292 Gear 16T. } Compound.
 293 Gear 32T. }
 294 Gear 16T. } Compound.
 295 Gear 32T. }
 296 Gear 16T. } Compound.
 297 Gear 32T. }
 298 Gear 16T.
 299 Gear 16T.
 300 Lever Gear 20T.
 301 Collar.
 302 Intermediate Shaft.
 303 Gear Lever Shaft.
 304 Input Shaft.
 305 Lead Screw Gear.
 307 Pin (Gear Box).
 308 Knob (Gear Box).
 309 Plunger (Gear Box).
 311 Key (Input Shaft).
 312 Key (Inter Shaft).
 313 Guide Plate (English).
 314 Pin (Guide Plate).
 315 Lever Gear 32T.
 316 Bush.
 318 Lever Bush.
 319 Lead Screw Key.
 320 Needle Bearing.
 322 Oil Pad (Input Shaft).
 323 Oil Pad (Inter Shaft).
 324 Shaft Retaining Pin.
 325 Pin (Lever Bush).
 326 Lead Screw Collar.
 327 Plug.
 328 Gearbox Chart (Metric).
 329 Change Gear Guard.
 330 Countershaft Guard.
 331 Pin (Countershaft Guard).
 332 Spacing Bush.
 333 Spacing Bush.
 390 Tailstock Clamp Eccentric.
 391 Tailstock Clamp Pin.
 392 Tailstock Clamp Handle.
 393 Apron Lever Pin.
 394 Foot Adjusting Screw.
 395 Washer.
 396 Gib Strip Slug.
 397 Clamp (Tailstock Spindle).
 398 Clamp (Tailstock Spindle).
 399 Belt Tension Handle.
 400 Switch Bracket.
 401 Tailstock Stop Pin.
 402 Reverse Gear Bracket.
 403 Plunger.
 404 Finger.
 405 Handle.
 406 Knob.
 407 Pivot Pin.
 408 Spring.
 409 Retaining Piece.
 410 Motor.
 411A V-Belt A.33.
 411B V-Belt A.34.
 411C V-Belt A.35.
 412A V-Belt A.36.
 412B V-Belt A.39.
 413 Grease Lubricator.
 414 Right Angled Snap Lid Oiler.
 415 Ball Journal.
 416 Taper Roller Bearing (Front).
 417 Taper Roller Bearing (Rear).
 418 Bush.
 480 Countershaft Base.
 481 Countershaft Bracket.
 482 Countershaft Upright.
 483 Loose Bracket.
 484 Bracket.
 485 Motor Platform.
 486 Countershaft Pivot.
 487 Eye Bolt.
 488 Eye Bolt Stud.
 489 Motor Adjustment Nut.
 490 Motor Pivot Pin.
 491 Belt Adjustment Screw.
 492 Nut.
 493 Shifter.
 494 Eccentric.
 495 Collar.
 496 Handle Bush.
 497 Handle.
 498 Stop Pin.
 499 Compression Spring.
 500 Countershaft Guard.
 501 Spacing Bush.
 502 Latch.
 503 Retaining Screw.
 504 Guard Stop Bar.
 505 Guard Stop Pin.
 506 Countershaft Guard (Standard).
 507 Countershaft Guard (Switch Brt.).
 551 Foot.
 552 Countershaft (C.S.B.).
 553 Pivot Bracket.
 554 Tension Bracket.
 555 R.H. Eye Bolt.
 556 L.H. Eye Bolt.
 557 Tension Nut.
 558 Retaining Screw.
 559 Pivot Screw.
 560 Pin.
 562 Spindle.

- 563 Washer.
 564 Switch Box.
 565 "For-Rev" Escutcheon.
 566 "On-Off" Escutcheon.
 567 Handwheel (C.S.B.).
 568 Foot Packing Piece (C.S.B.).
 569 8" Pulley (C.S.B.).
 570 2" Pulley (C.S.B.).
 571 4½" Handwheel.
 572 Guard Spacing Piece (2").
 573 Countershaft Guard (C.S.B.).
 574 Hinge Block.
 575 Washer.
 576 Countershaft V-Pulley.
 577 Pin.
 578 "T-Slot" Cross Slide.
 579 Anchor Bracket.
 580 Countershaft.
 581 Countershaft Base.
 582 Motor Platform.
 583 Countershaft Guard.
 584 Guard Spacing Piece (1").
 585 Tool Post Body.
 586 Clamping Stud.
 587 Handle.
 588 Grip Handle.
 601A Foot (Headstock).
 601B Foot (Tailstock).
 602 Spindle Pulley.
 602TUD Spindle Pulley (Training Lathe).
 603 Hardboard Cover.
 604 Speed Chart.
 605 Handle.
 606 Handle Boss.
 607 Support Plate.
 608 Release Shaft.
 609 Collar.
 610 Angle Bracket.
 611 Stop Pin.
 612 Eccentric.
 613 Pivot Bush.
 614 Shifter.
 615 Tie Rod.
 616 Eye Bolt.
 617 Screw Pin.
 618 Large Bush.
 619 Intermediate Shaft.
 620 Collar (1").
 621 Intermediate Pulley.
 622 Small Bush.
 623 Pivot Bracket.
 624 Pivot Screw.
 625 Motor Platform.
 626 Countershaft Pulley.
 627 Countershaft Spindle.
 628 Pulley Key.
 629 Washer.
 630 Locking Collar.
 631 6" Pulley (State Bore Size).
 632 Key.
 633 3" Pulley.
 634 Motor Key.
 635 Guard Flap.
 636 Guard Hinge.
 637 Guard.
 638 Guard Extra.
 639 Guard (TUD).
 640 Cabinet (36", 42", 48").
 641 Suds Tank Lid (36", 42", 48").
 642 Cover Plate.
 643 2½" Pulley.
 644 Cabinet Lubrication Chart.
 646 Motor Fixing Nut.
 647 Countershaft Spindle.
 648 Rack (Gap Pieces).
 649 Gap Piece.
 650 Gap Bed.
 651 Headstock (Mk II).
 652 Guard Plate.
 652A Guard Plate Hinge.
 653 Guard.
 654 Gear Lever.
 655 Back Gear Shaft.
 656 Back Gear 62T.
 657 Back Gear Sleeve 24T.
 658 Spindle Gear 38T.
 659 Spindle Pulley.
 660 Drive Pin.
 661 Compression Spring.
 662 Retaining Piece.
 663 Spindle Sliding Gear 76T.
 664 Spacing Washer.
 665 Main Spindle.
 666 Locknut.
 667 Shoe (Phos. Brz.).
 667A Shoe (Hdn. Steel).
 668 Gear Shifter Bar.
 669 Gear Shifter Spindle.
 670 Gear Shifter Boss.
 671 Bush.
 672 Pin (Pivot).
 673 Plunger.
 674 Gear Lever Spring.
 675 Spindle Lock Plunger.
 676 Spindle Lock Bush.
 677 Spindle Lock Spring.
 678 Screwed Pin.
 679 Top Plate.
 680 Rear Guard.
 681 Headstock Nameplate.
 682 Locating Bush.
 683 Switch Locking Screw.
 684 Switch Actuating Pin.
 685 Switch Cover Plate.
 686 Switch Spacing Bush.
 687 Slug (Locknut).
 688 Slug (Dial).
 689 Spring (Dial).
 690 Guard Spring.
 691 Button.
 692 Catch.
 693 Guard Switch Bracket.
 694 Terminal Box.
 695 Input Shaft.
 696 Inter Shaft.
 697A Inter Shaft Pinion 16/32T.
 697B Inter Shaft Pinion 16/32T.
 698 Outer Shaft Pinion 16/32T.
 699 Collar.
 700 Gear 30T.
 701 Thrust Washer.

702	Key.	764	Spindle Gear 48T.
703	Gear 18T.	765	Spacing Collar.
704	Output Shaft.	766	Pulley Gear 44T.
705	Coupling.	767	Spindle Pulley.
706	Guide Plate (Metric).	768	Spacing Washer.
707	Metric Lead Screw (36", 42", 48").	769	Sliding Gear 80T.
708	Change Gear 30T.	770	20T. Back Gear Shaft.
709	Change Gear 38T.	771	56T. Back Gear.
710	Change Gear 45T.	772	R.H. Bush.
711	Compound Gear 127/135T.	773	L.H. Bush.
712	Guard Plate Cover.	774	Gear Shifter Bar.
713	Quadrant Spacing Ring.	775	Front Cover.
714	Housing.	776	Rear Cover.
715	Vertical Screw.	777	Key (Screw Fixing).
716	Nut.	777A	Key (Pin Fixing $\times \frac{7}{8}$ " long).
717	Bearing Cover.	777B	Key (Pin Fixing $\times 1\frac{1}{4}$ " long).
718A	Trunnion Lever.	778	Draw Nut (Complete Assembly).
718B	Trunnion Lever.	778A	Outer Ring (Draw Nut).
719	Strap.	778B	Inner Ring (Draw Nut).
720	Handwheel.	778C	Key (Draw Nut).
721	Remote Control Assembly.	779	Key (Spindle Nose).
722	Bracket.	780	Reverse Gear Bracket.
723A	Hanger (Sens. Hd.).	781	Reverse Gear Spindle.
723B	Hanger.	782	48T. Rev. Gear Follower.
724	Strap (Sens. Hd.).	783	Pillar.
725	Plummer Block.	784	32T. Reverse Gear.
726	Shaft (Inter).	785	Reverse Gear Stud.
727	Rotor.	786	Washer.
728	V/S Pulley (Spring).	787	Plunger.
729	V/S Belt (P.444).	788	Anchor Bracket.
730	Key.	789	Draw Bar Handwheel (5C).
731	Motor Key.	790	Drawtube (5C).
732	V/S Pulley (Manual).	791	Collet Adaptor (5C).
733	Bush.	792	Pin (Collet Adaptor).
734	V/S Cabinet.	793	Nose Cap.
735	Coupling.	794	Catch Plate.
736	Spacing Washer.	794A	Balance Peg.
737	Key.	794B	Driver Pin.
738	2 $\frac{1}{2}$ " Pulley (1").	795	Face Plate (8 $\frac{7}{8}$ ").
739	Trans/Rect Box.	796	"C" Spanner.
740	Bush.	797	Back Shaft L.H. Bearing.
741	Mains Junction Box.	798	Back Shaft R.H. Bearing.
742	Junction Box Escutcheon.	799	Oil Retaining Bush.
743	Grip Handle.	800	
744	Socket Shoulder Screw.	801	Front Taper Roller Bearing.
745	12mm. Bearing.	802	Rear Taper Roller Bearing.
746	Light Duty Sensing Head.	803	Adaptor Sleeve (No. 3 Morse).
747	Intermediate Shaft.	804	No. 3 Morse Centre.
748	Tie Rod.	805	Splash Guard (Headstock).
749	Pivot Block.	806	Screw (Switch Actuating).
750	Eccentric.	807	Key (Spindle Gear).
751	Bracket.	808	Adaptor (Magnetic Brake).
752	Handle.	809	Link Bracket
753	2 $\frac{5}{8}$ " Pulley (1").	810	Link (LOO) } Lever Collet
754	3 $\frac{1}{8}$ " Pulley ($\frac{5}{8}$ ").	811	Pin. } Chuck.
755	5 $\frac{5}{8}$ " Pulley (1").	812	Link (Std.) }
756	3 $\frac{1}{2}$ " Pulley (1").	813	64T } Compound Gear.
757	Plate } Top Mounting	814	54T } Compound Gear.
758	Pillar } for Det. 721.	815	76T } Compound Gear.
759	Tachometer (0-2500).	816	65T }
760	Headstock Casting (LOO).	817	Disc Spring (Z8).
761	Spindle (LOO).	818	$\frac{3}{8}$ " Ball Journal (Double Shield).
762	Spindle Locknut (LOO).	819	$\frac{1}{2}$ " Ball Journal (Double Shield).
763	Spacing Washer.		

See note on page 20 for ordering spares or replacement parts, etc.

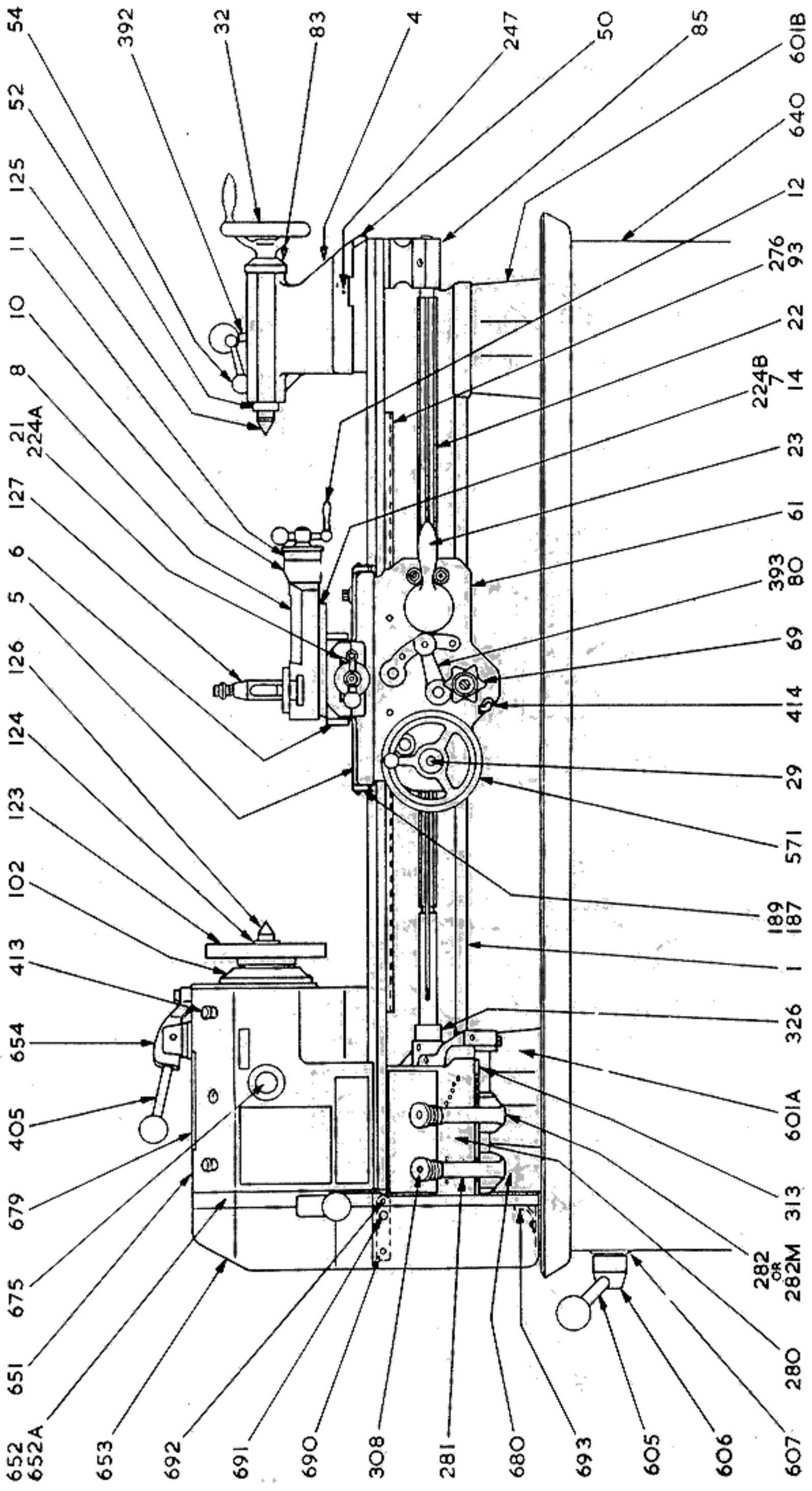

Diagram Z. General Arrangement Mk. II

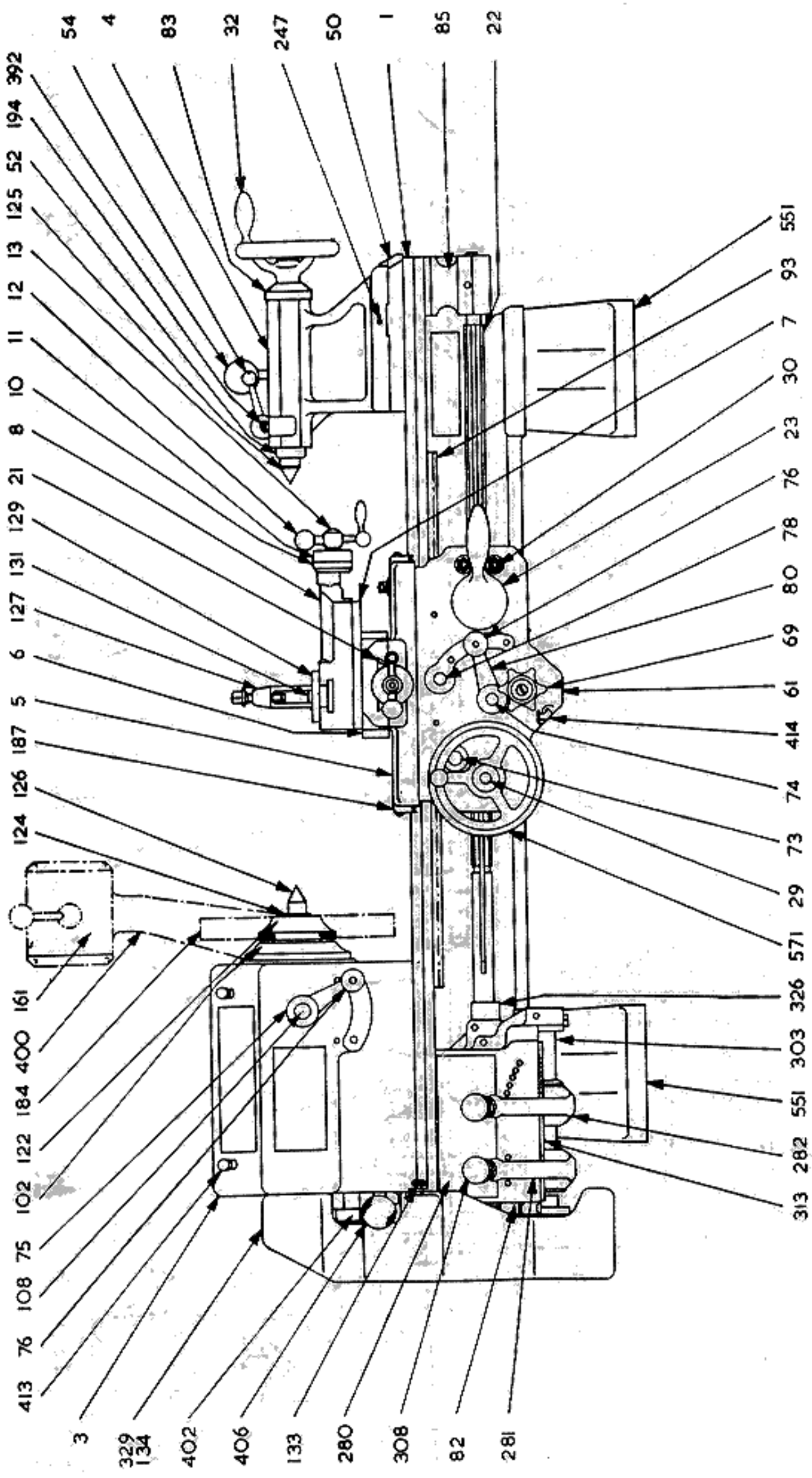

Diagram Y. General Arrangement

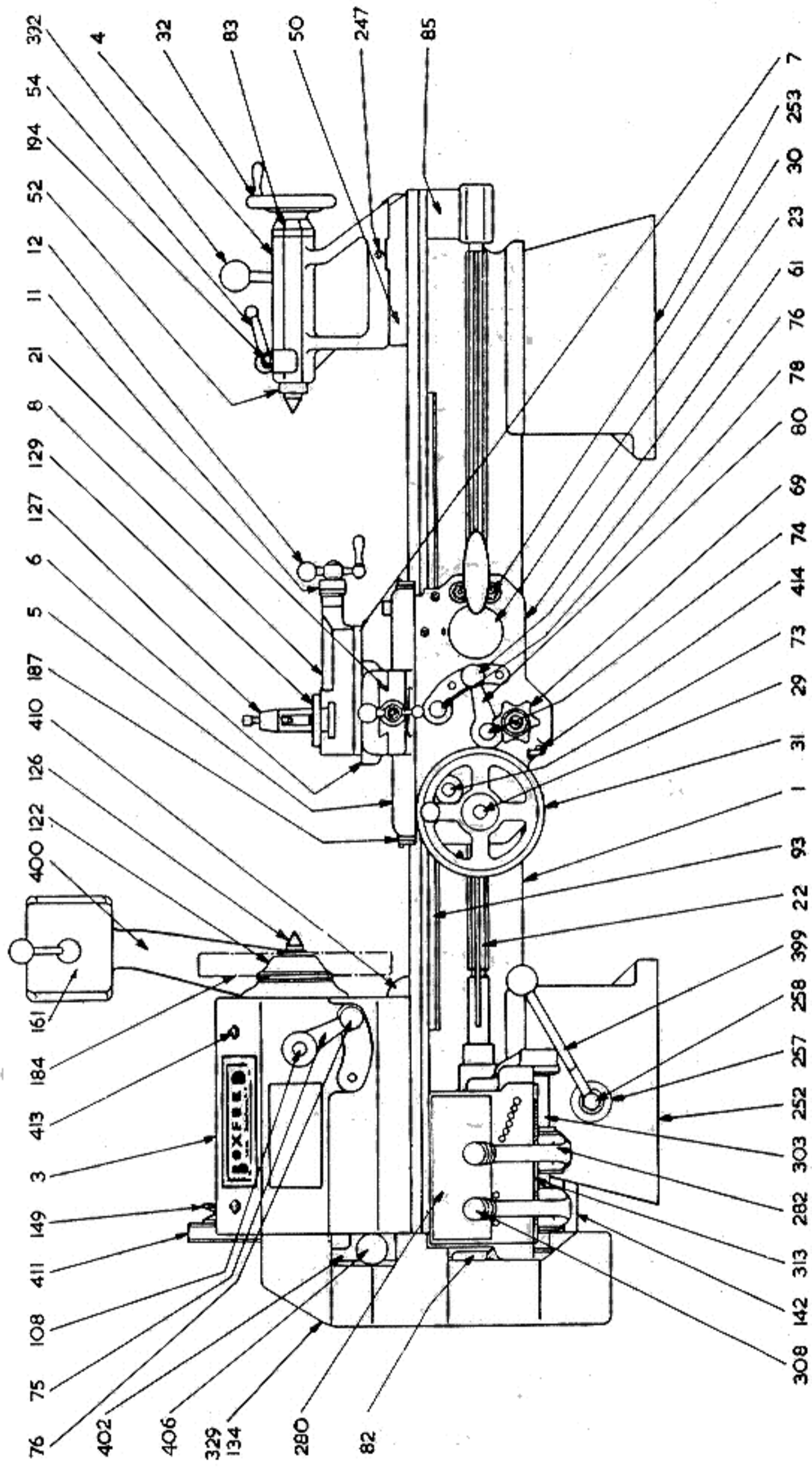
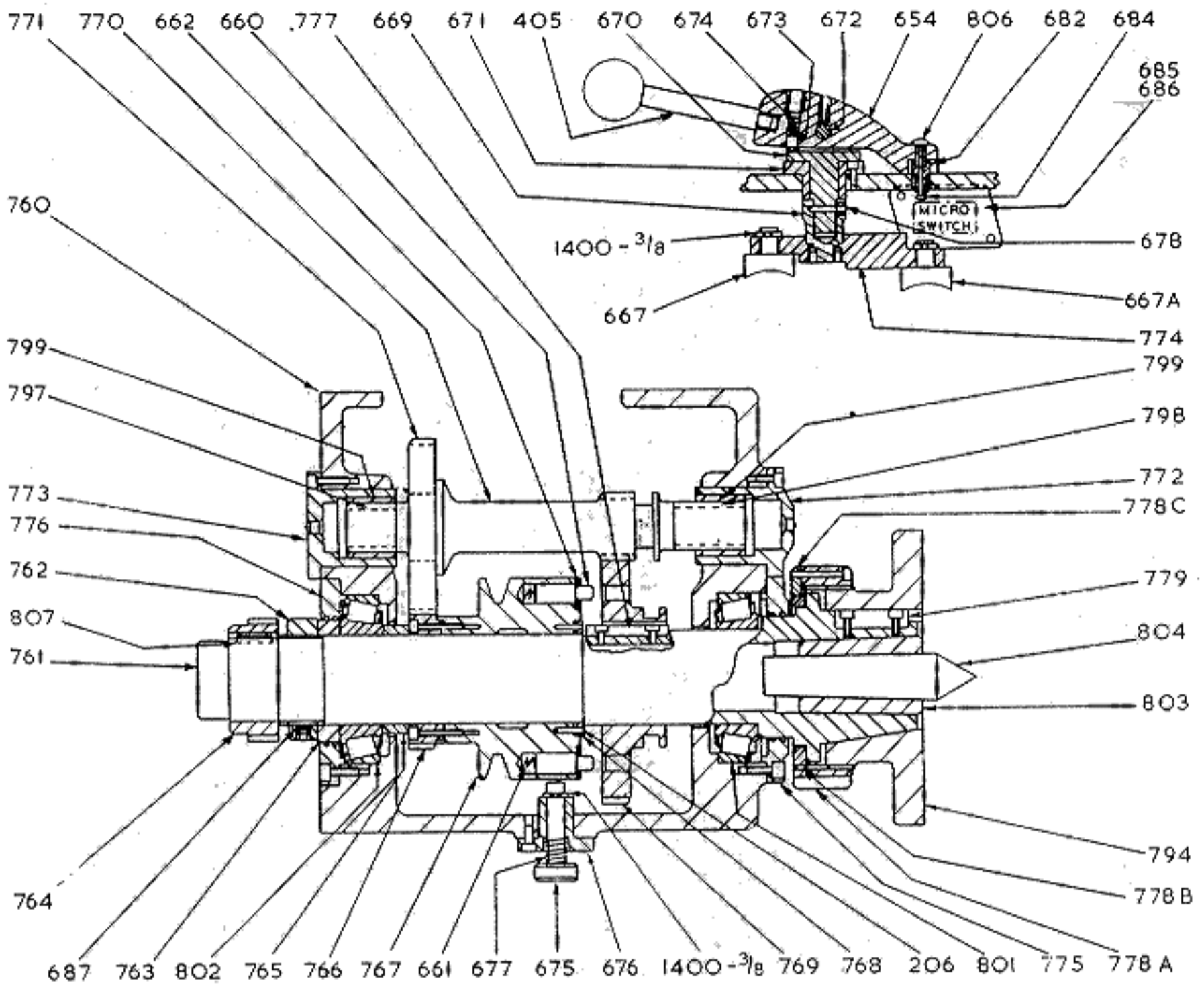
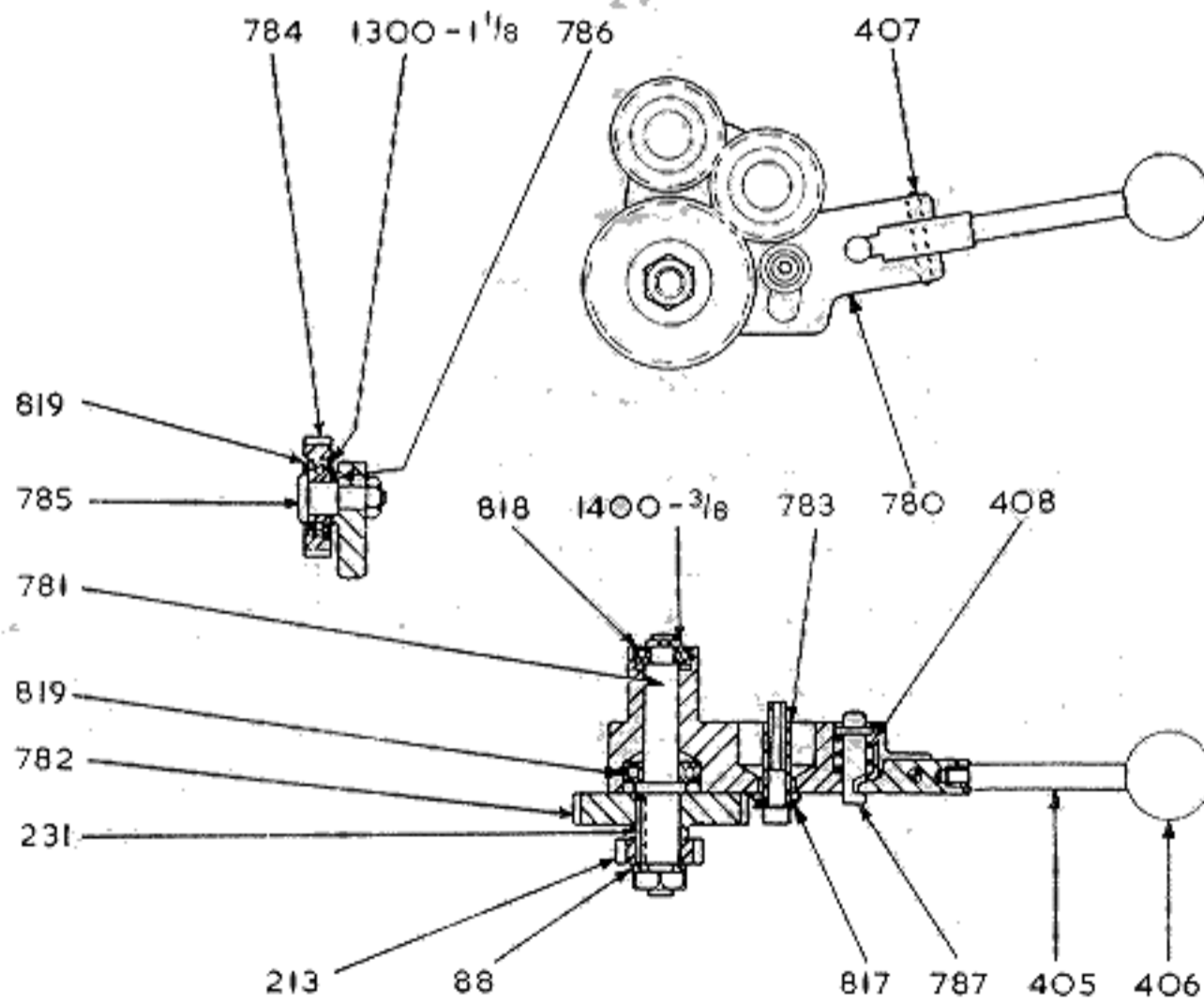

Diagram X. General Arrangement



Headstock LOO



Reverse Gear LOO

NOTE:

When dismantling LOO Headstock with key (777) fixed in spindle ensure that key is in 12 o'clock position, as this will enable the key to pass the slot in the casting, thus allowing the spindle to be readily withdrawn.

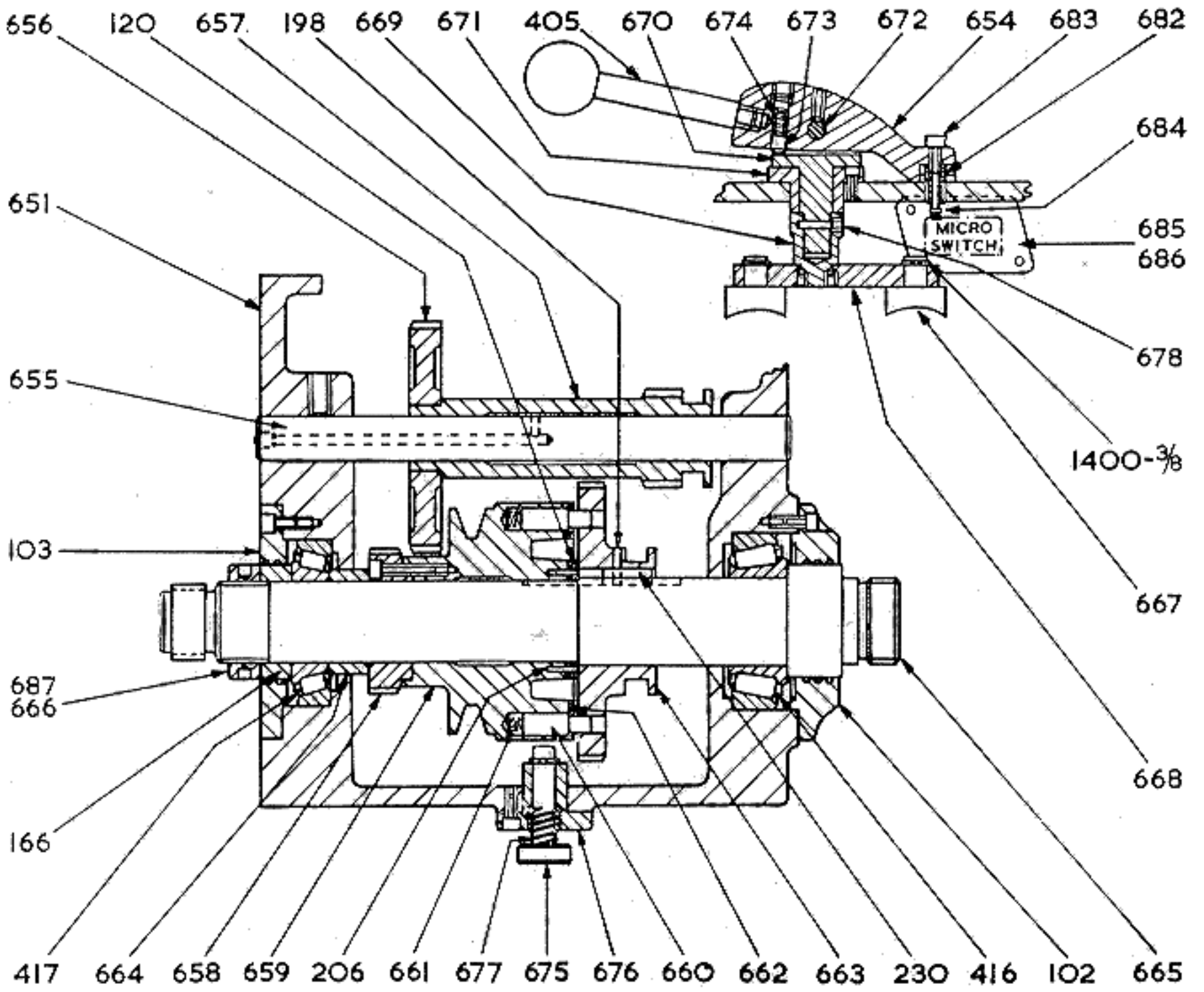

Diagram W. Headstock Mk. II

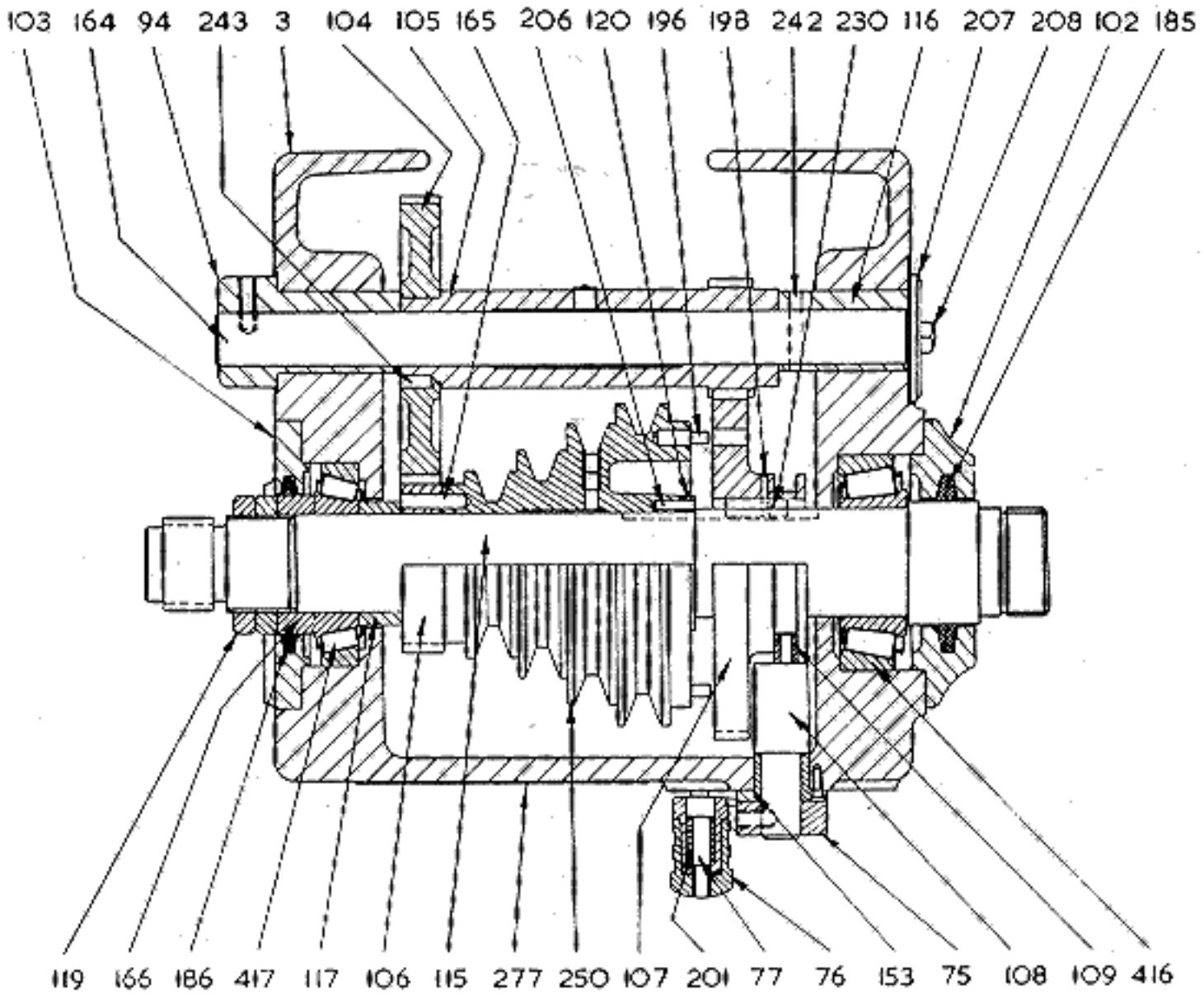

Diagram V. Headstock

NOTE: Detail 250 is replaced by 602 on Underdrive Mk. I Headstocks.

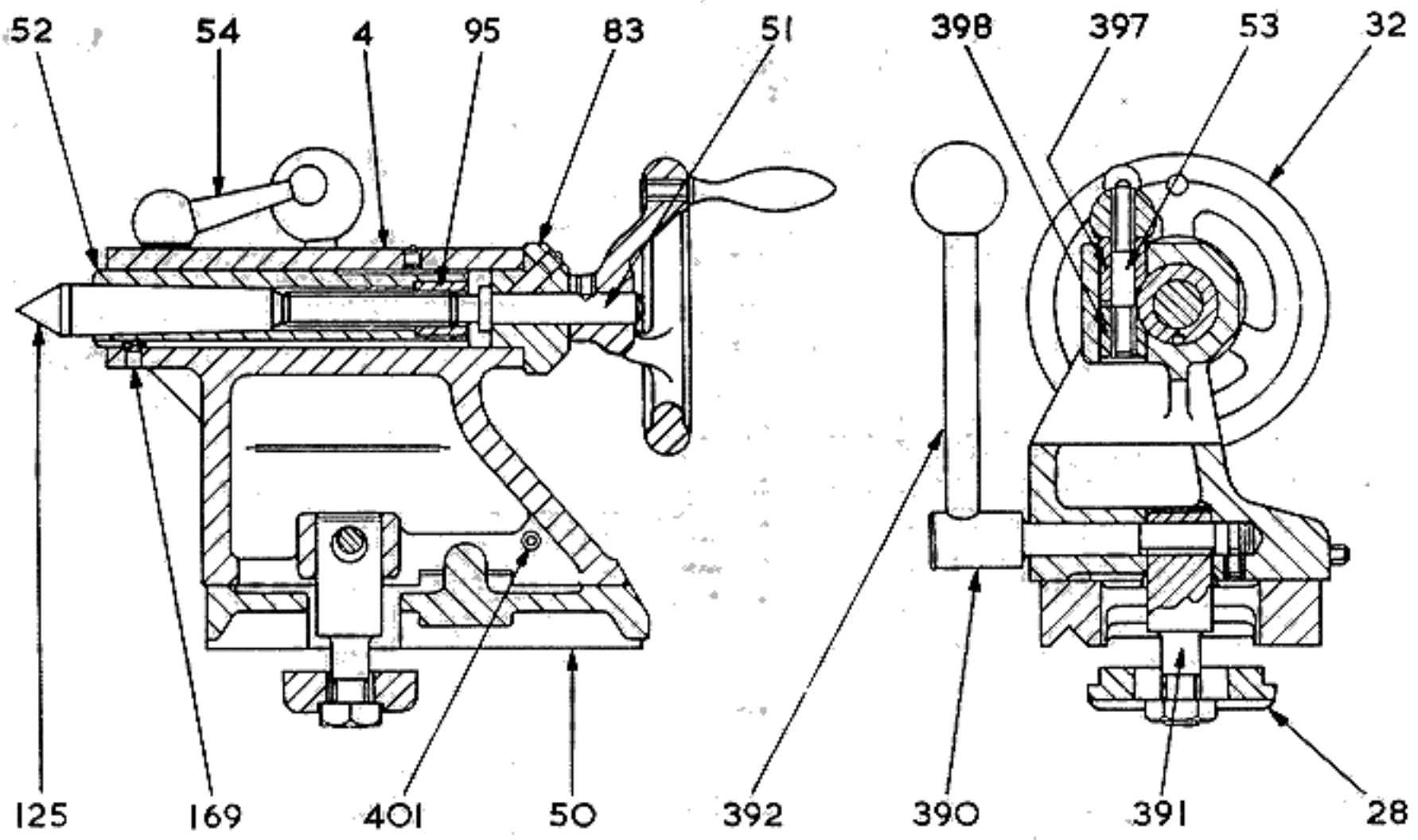

Diagram U. Tailstock

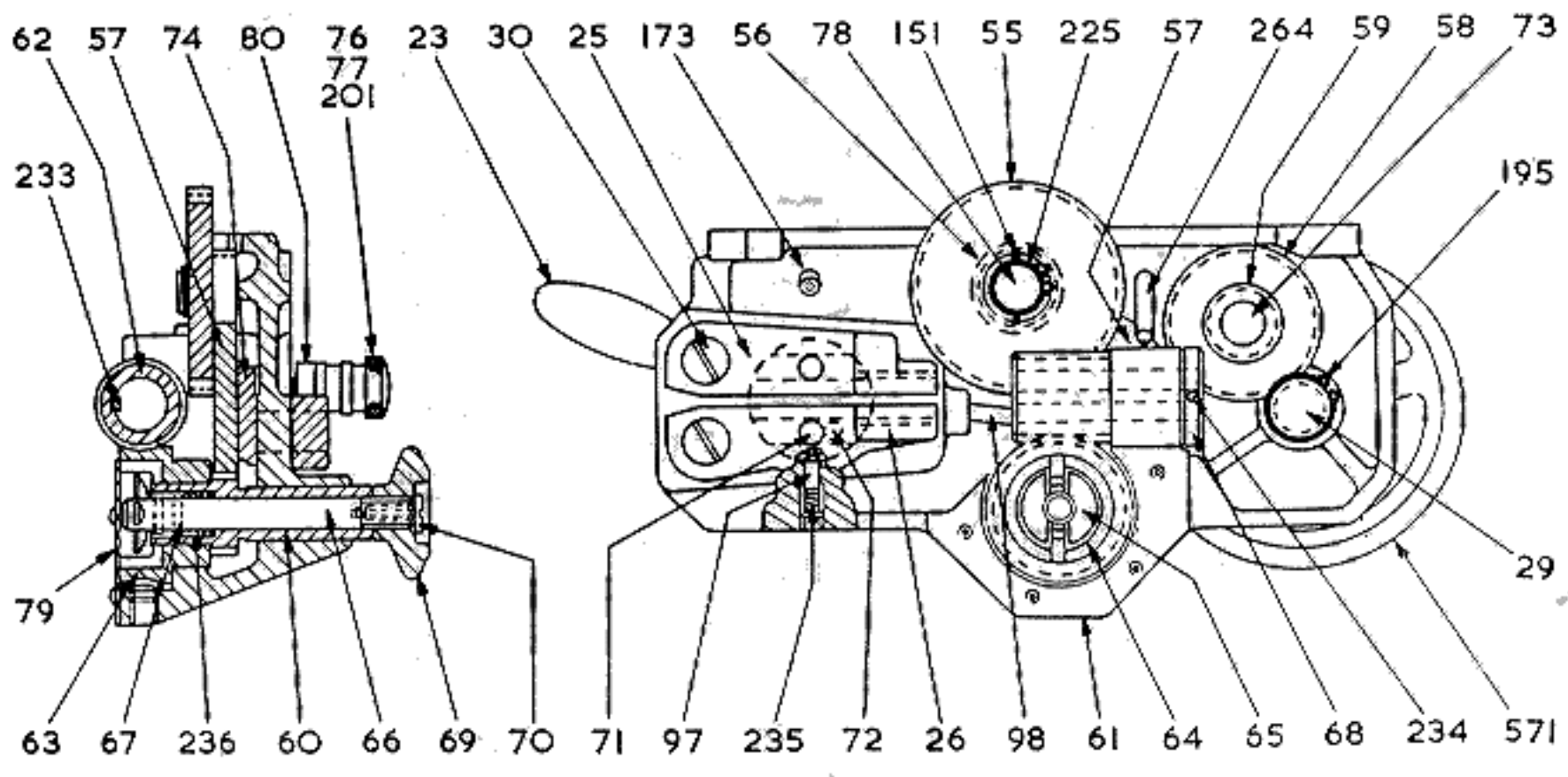

Diagram T. Automatic Apron (Models A and B)

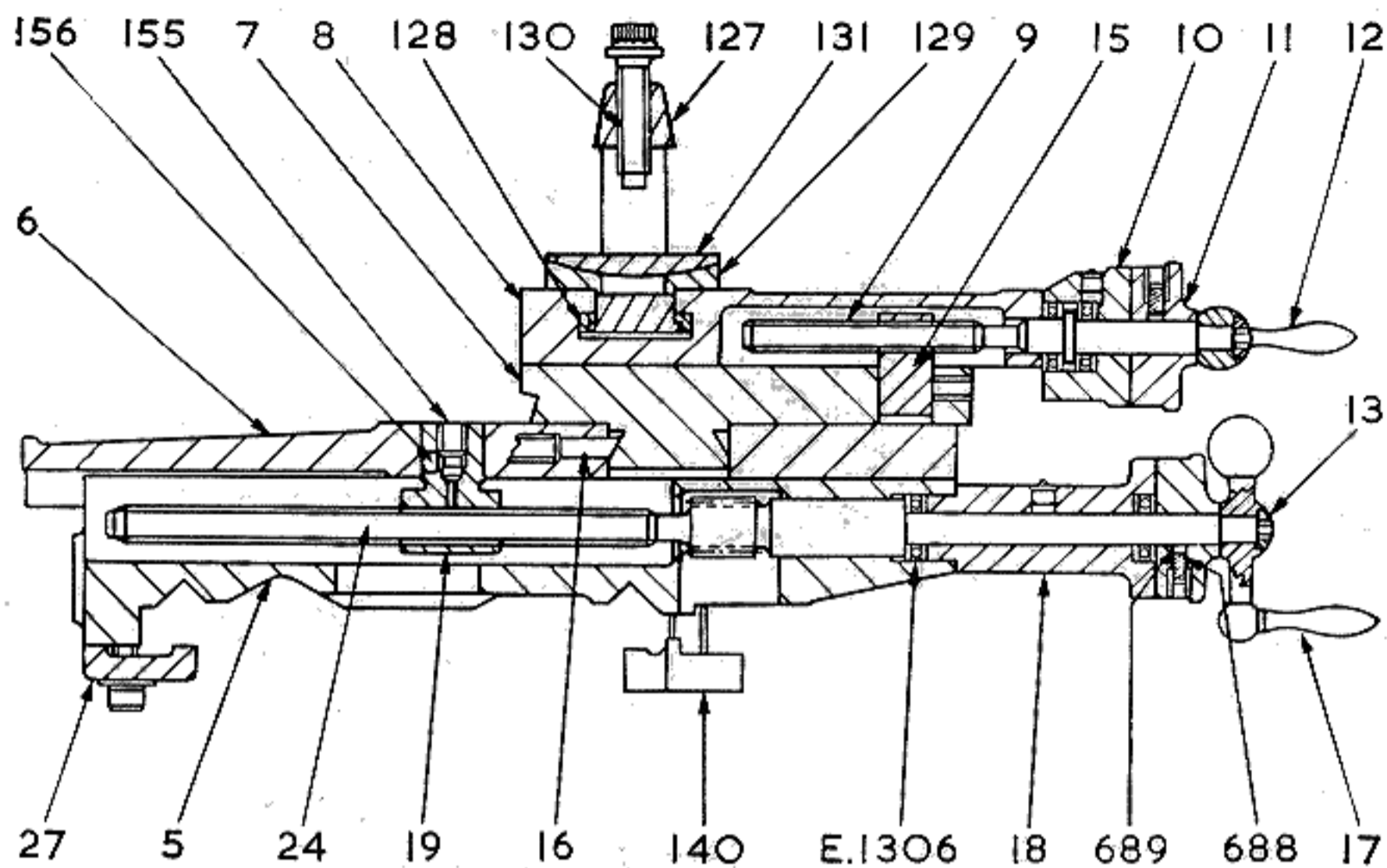

Diagram S. Saddle and Compound Rest

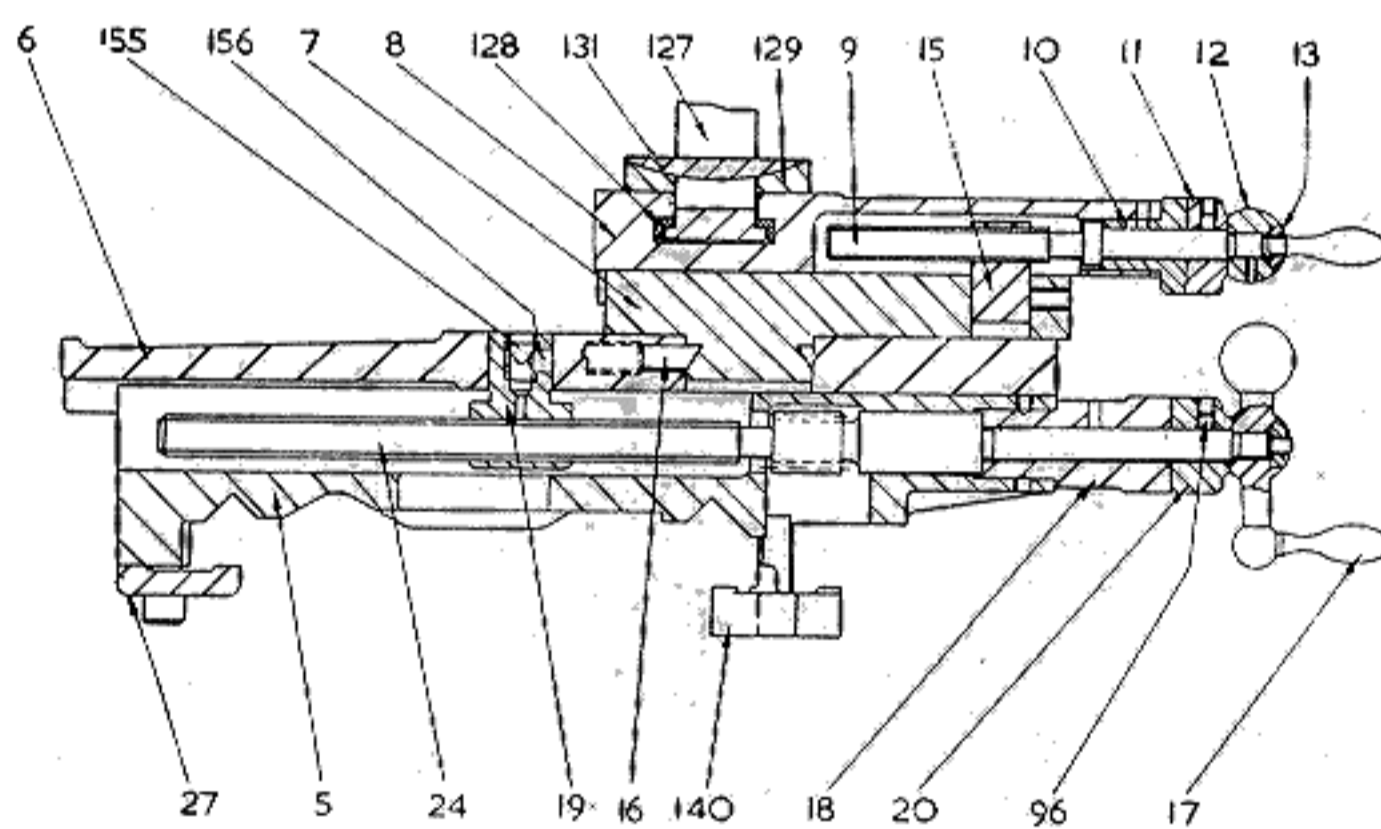

Diagram R. Saddle and Compound Rest

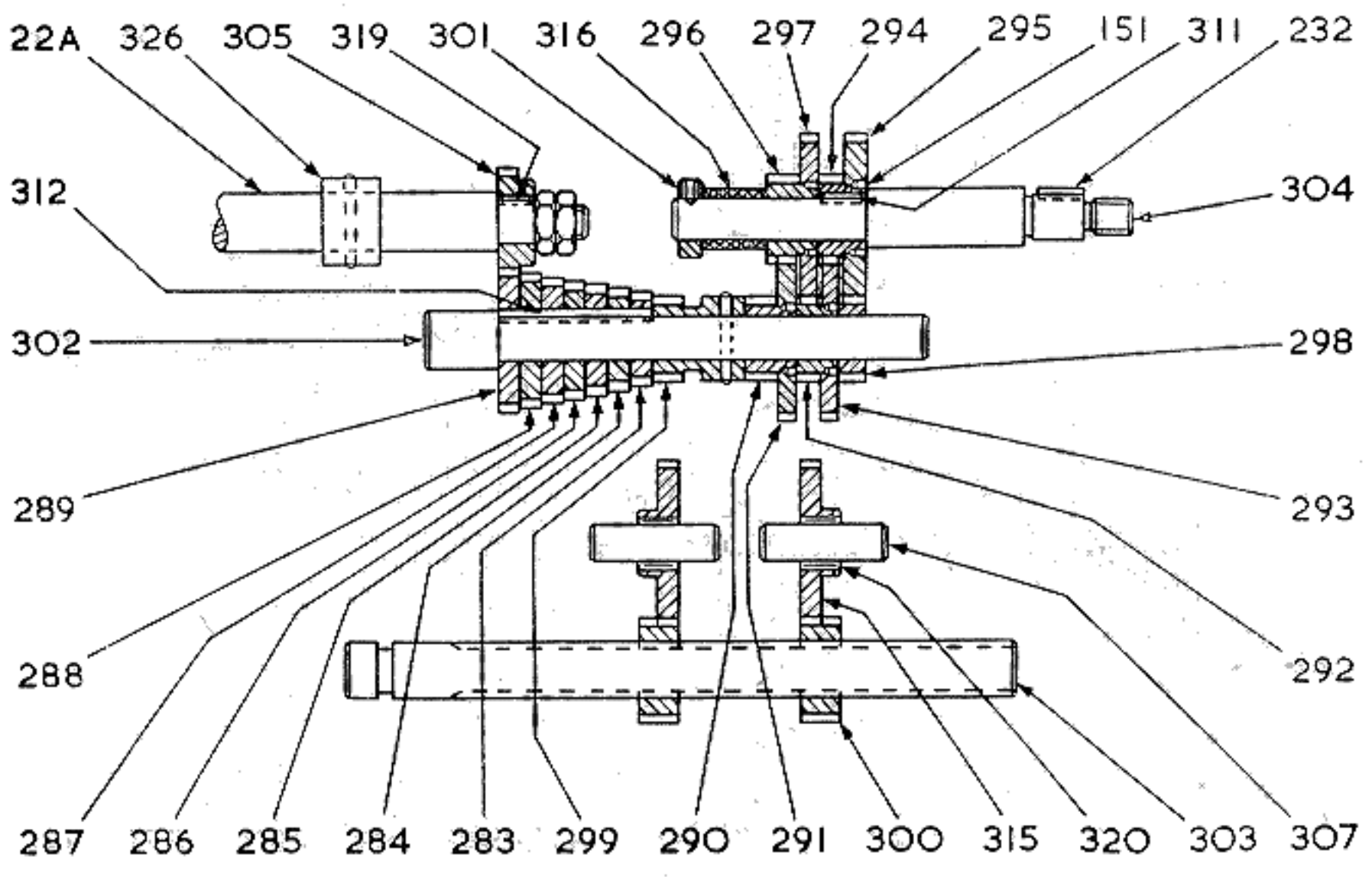

Diagram Q. Gearbox (English)

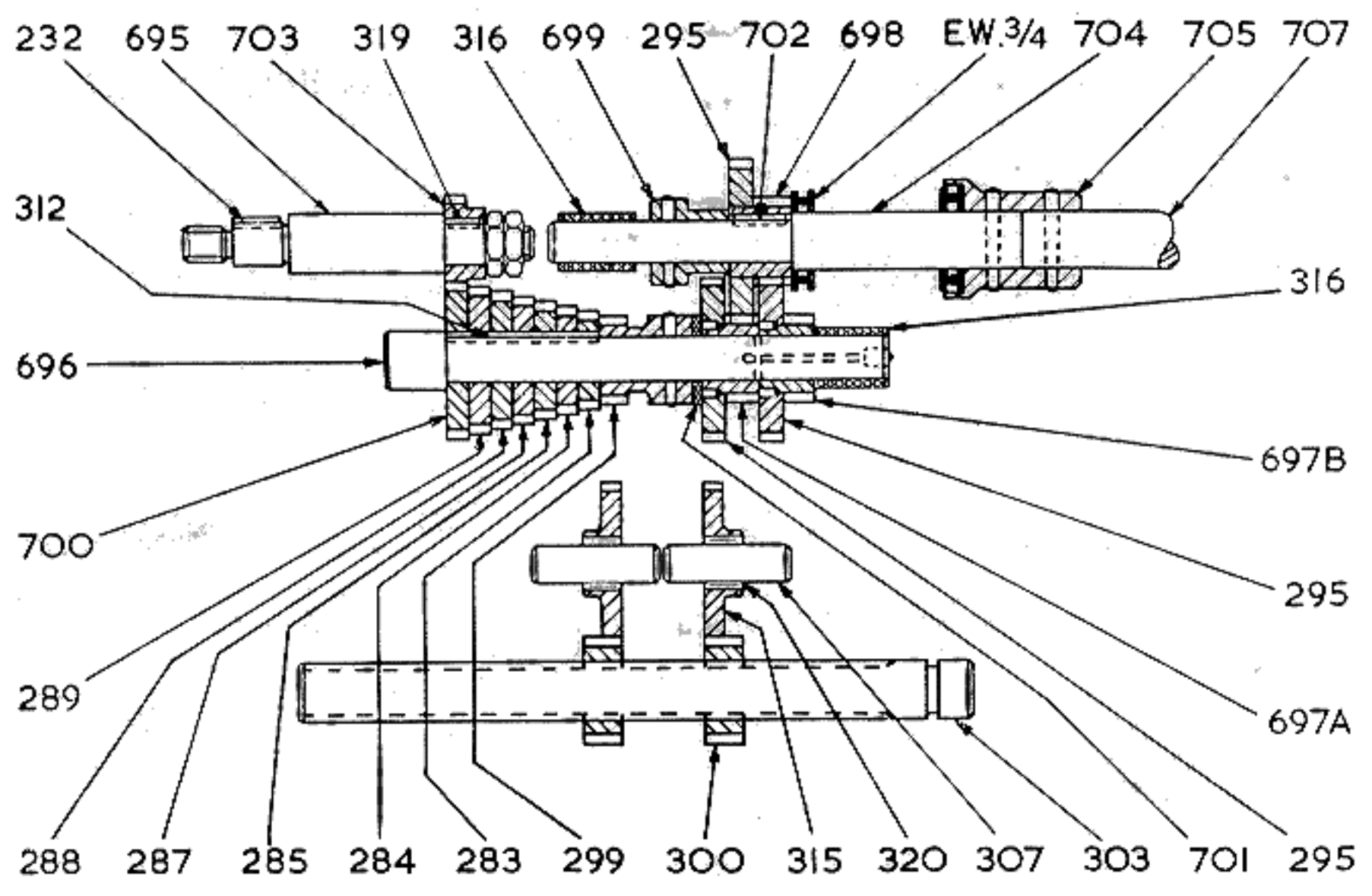

Diagram P. Gearbox (Metric)

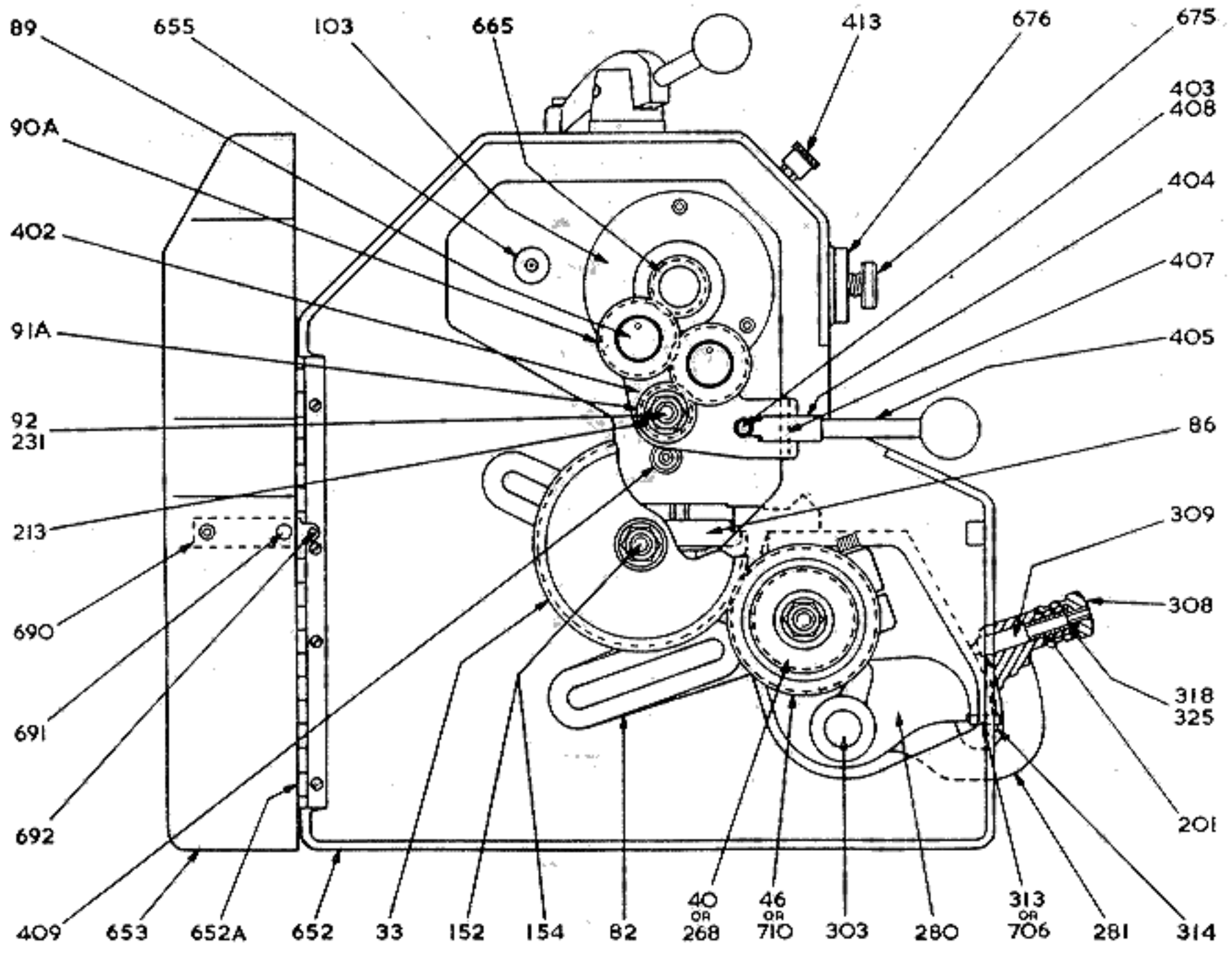

Diagram O. Gearing and Guard Mk. II

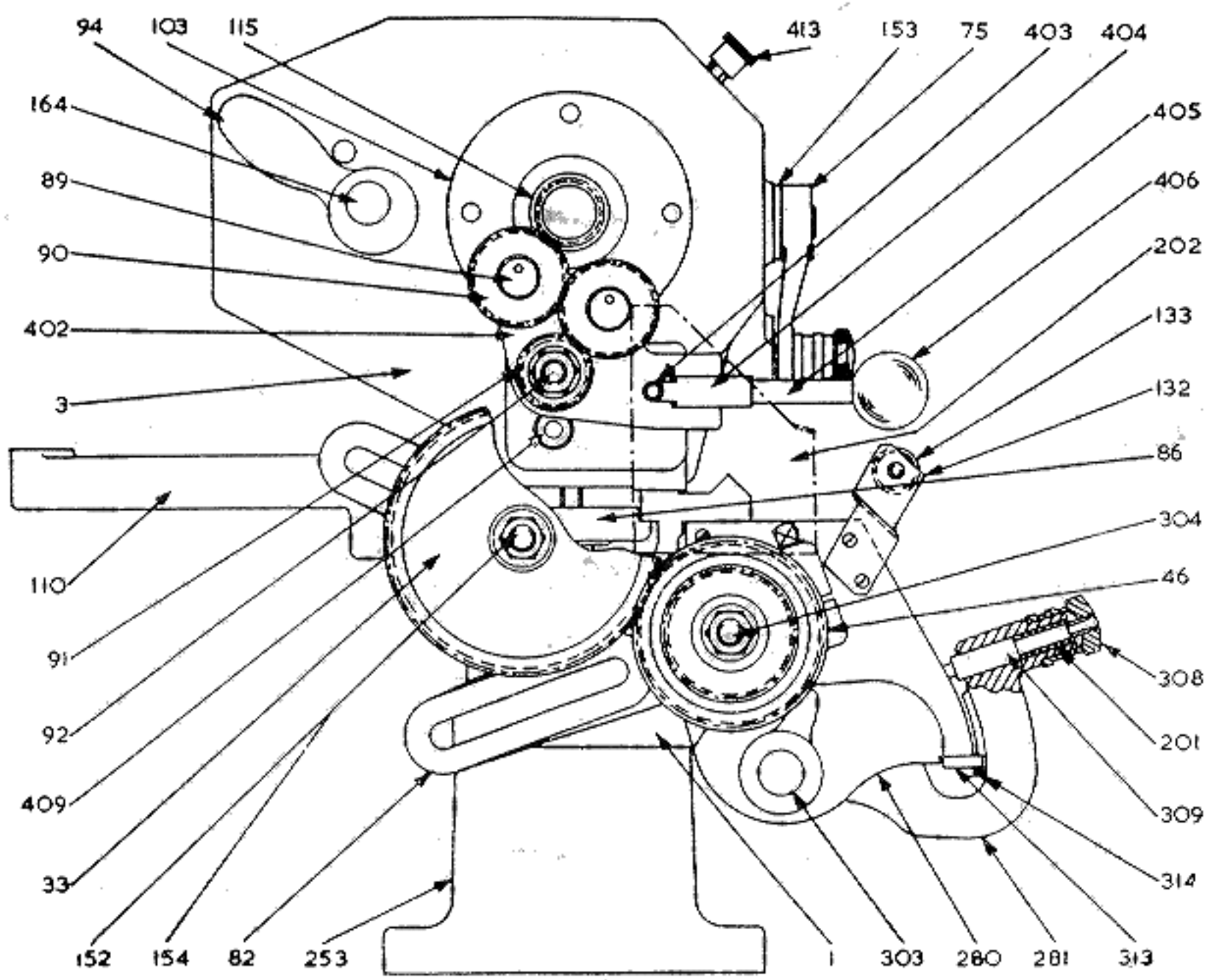

Diagram N. Gearing (Mk. I and Bench)

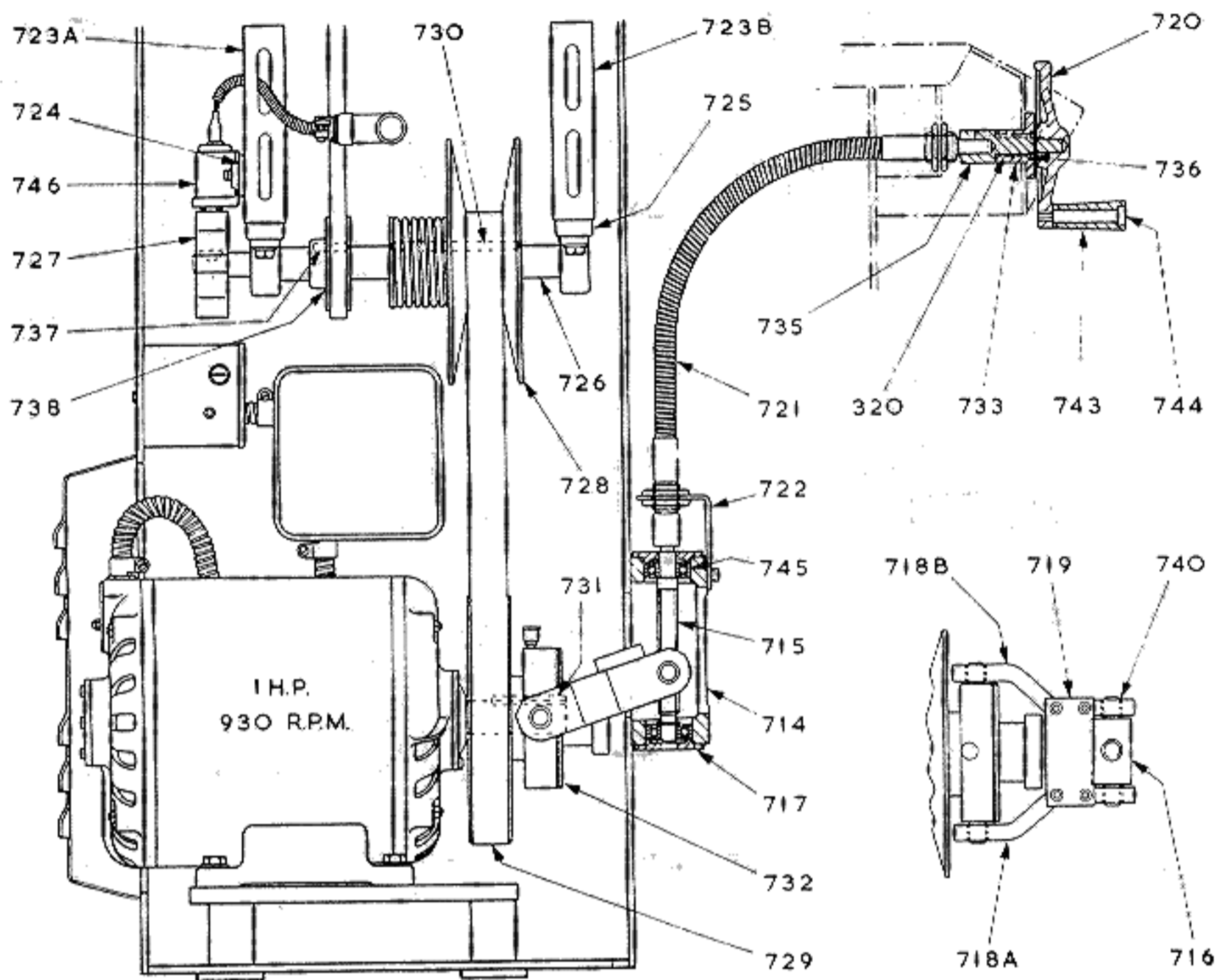

Diagram M. Vari-Speed Drive Unit

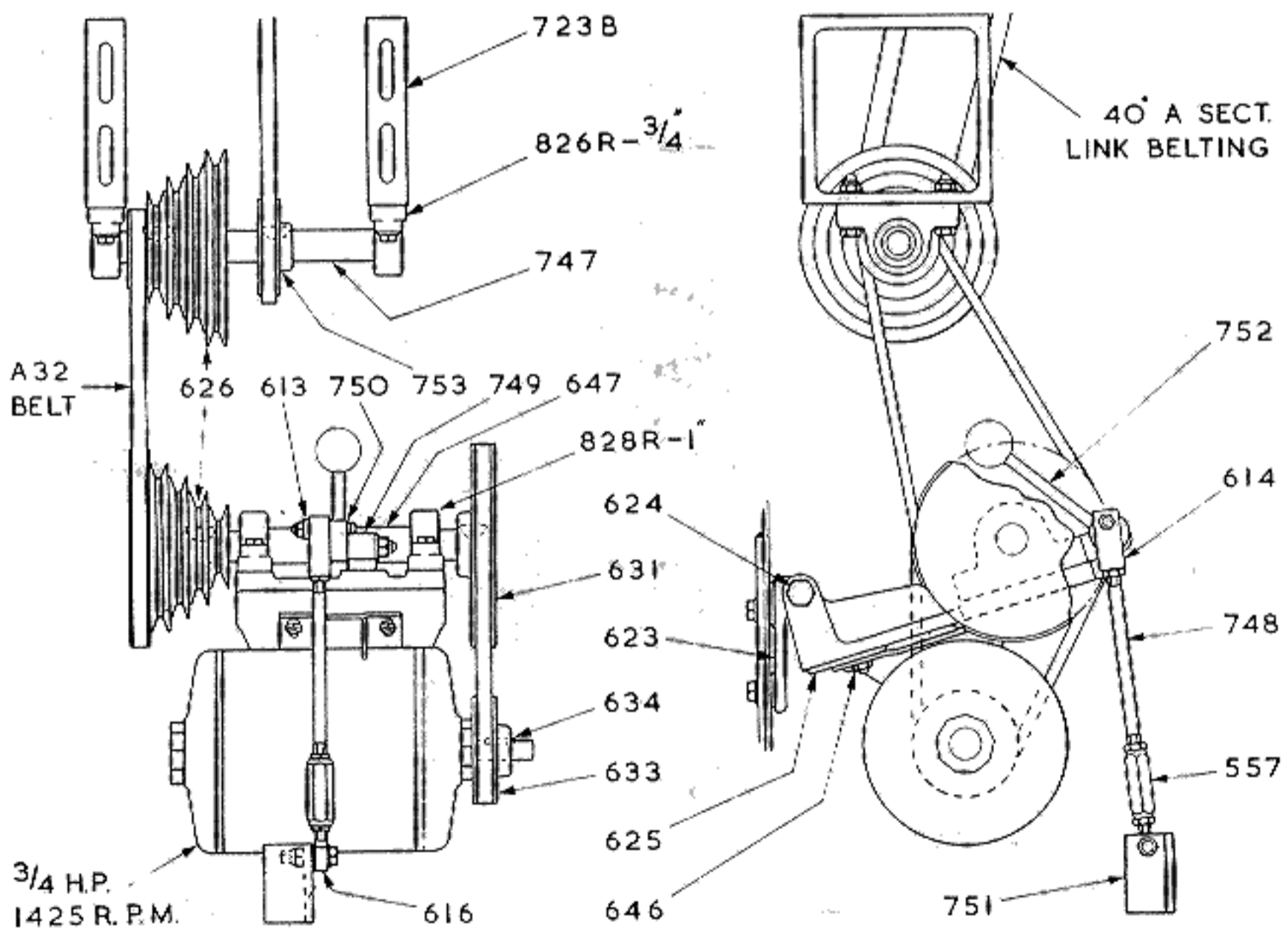

Diagram L. Standard Underneath Drive (1966 onwards)

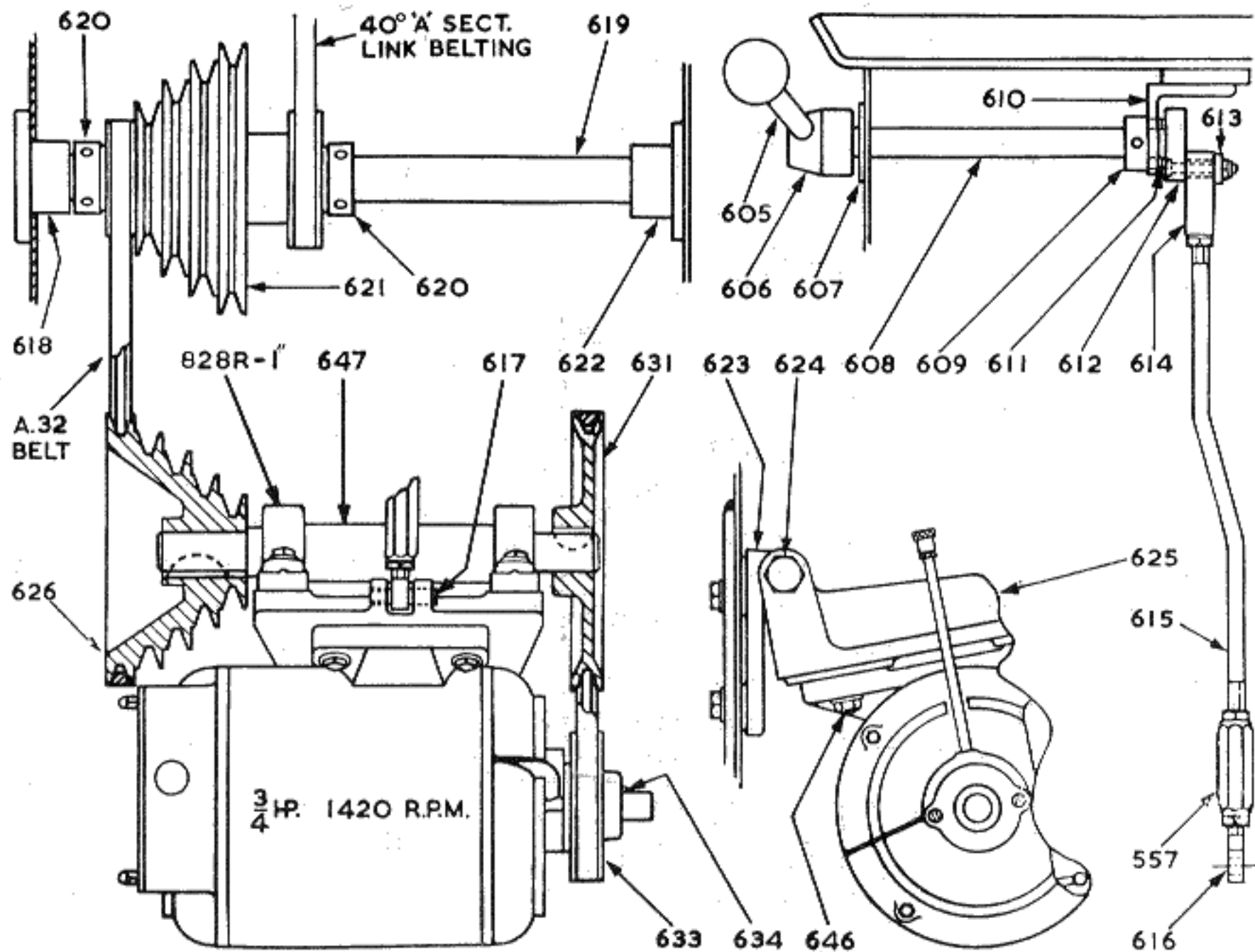

Diagram KA. Countershaft—Underdrive

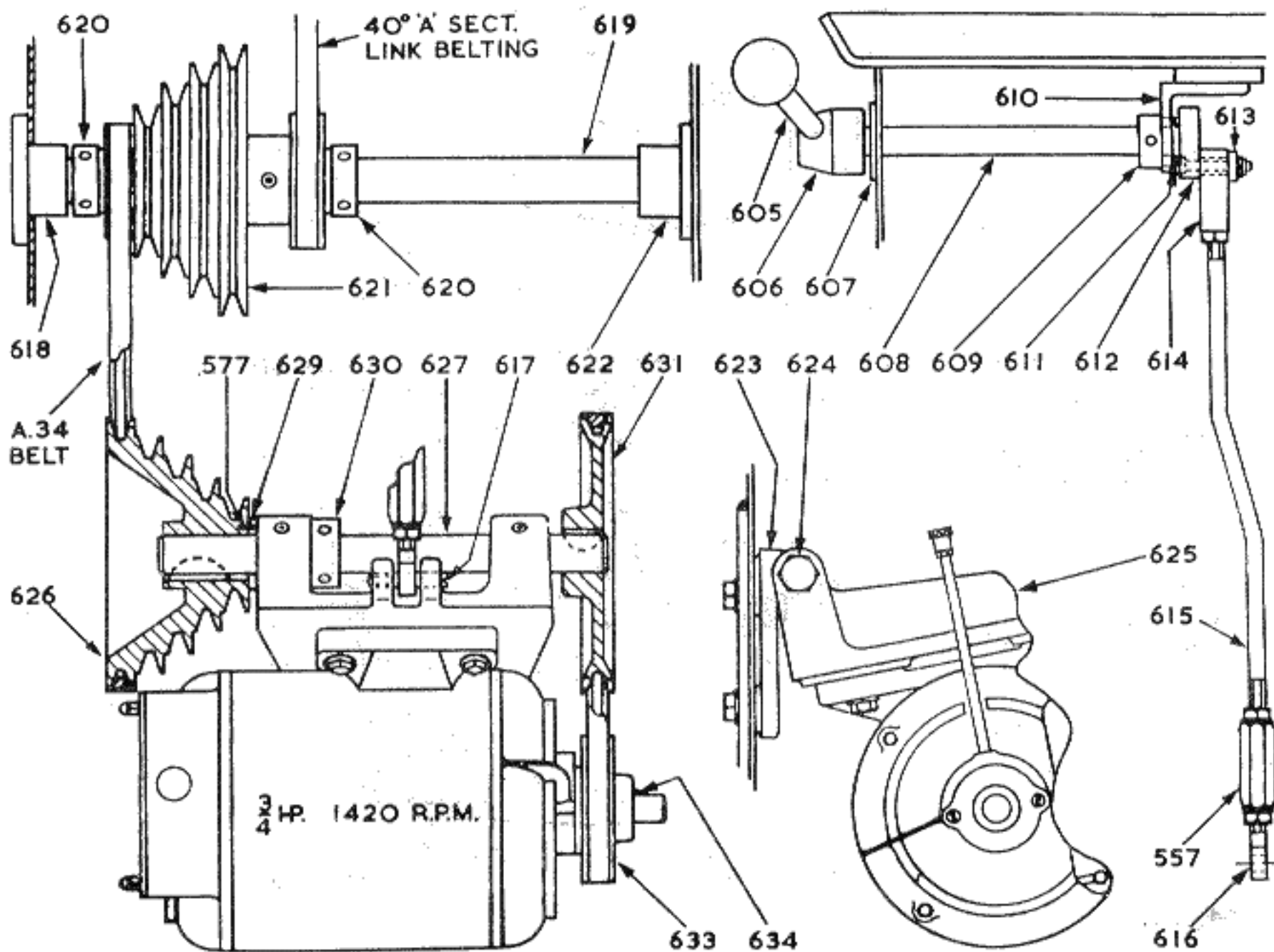

Diagram K. Countershaft—Underdrive

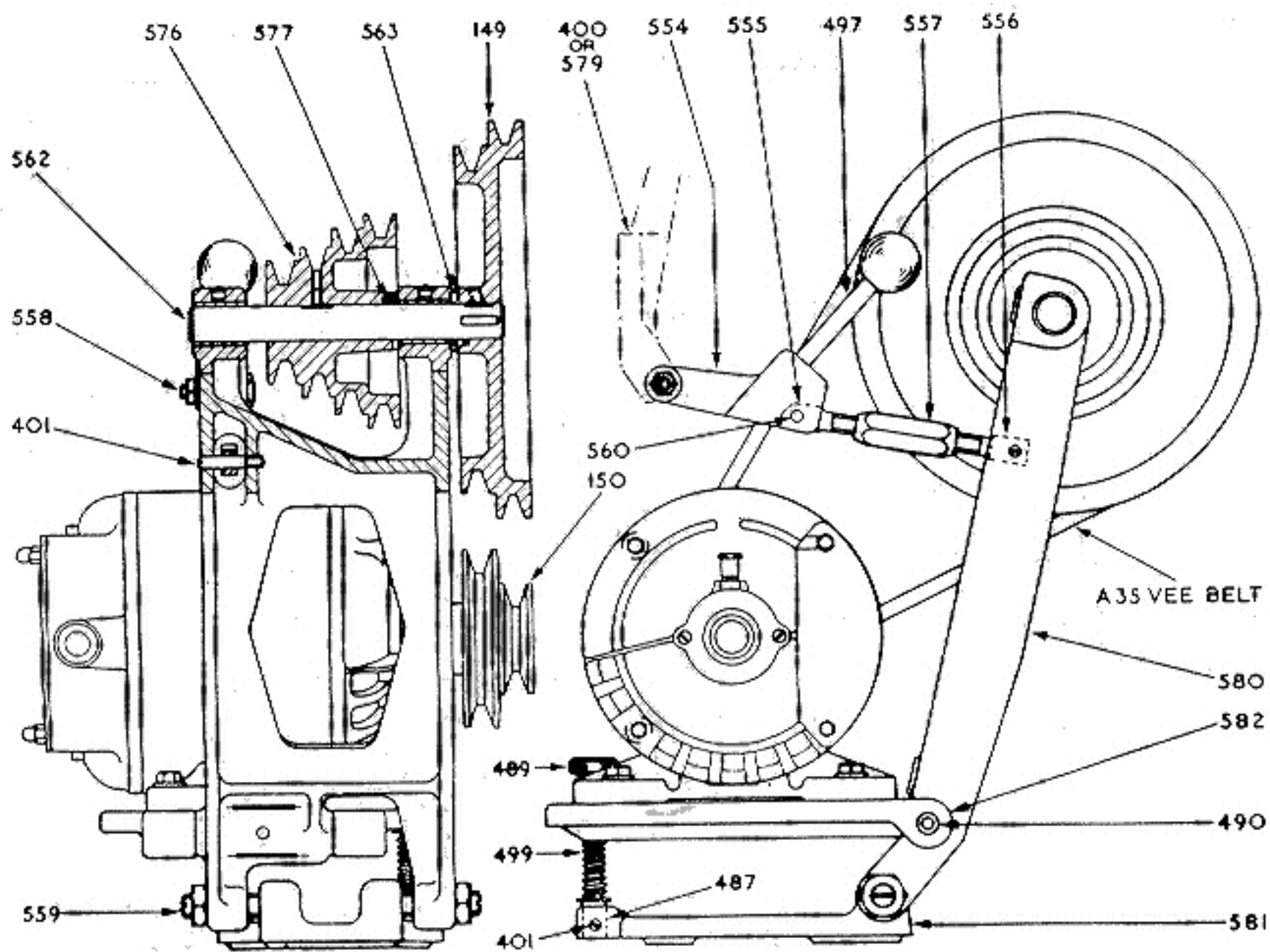

Diagram G. Countershaft (Models A, B and C)

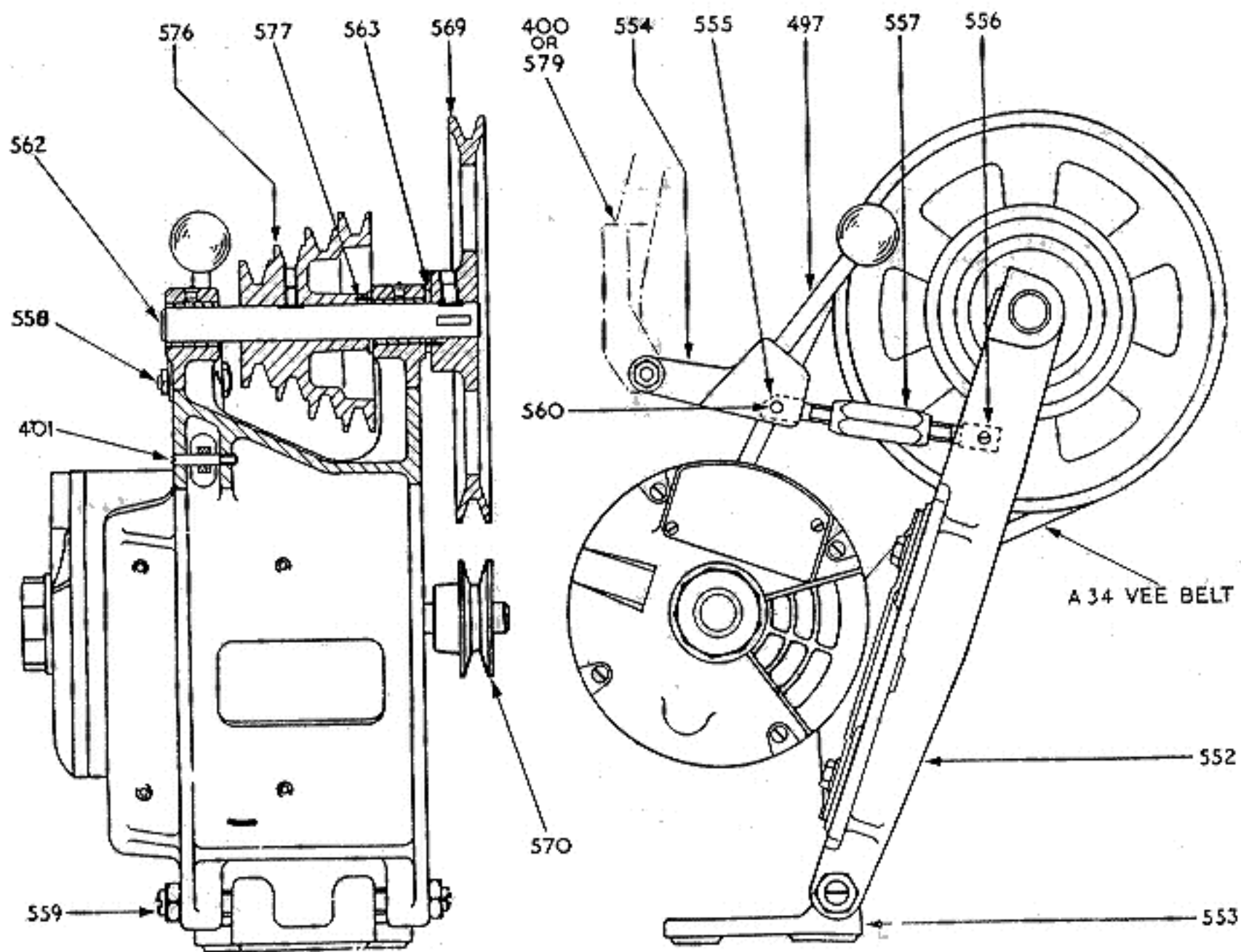

Diagram J. Countershaft—CSB

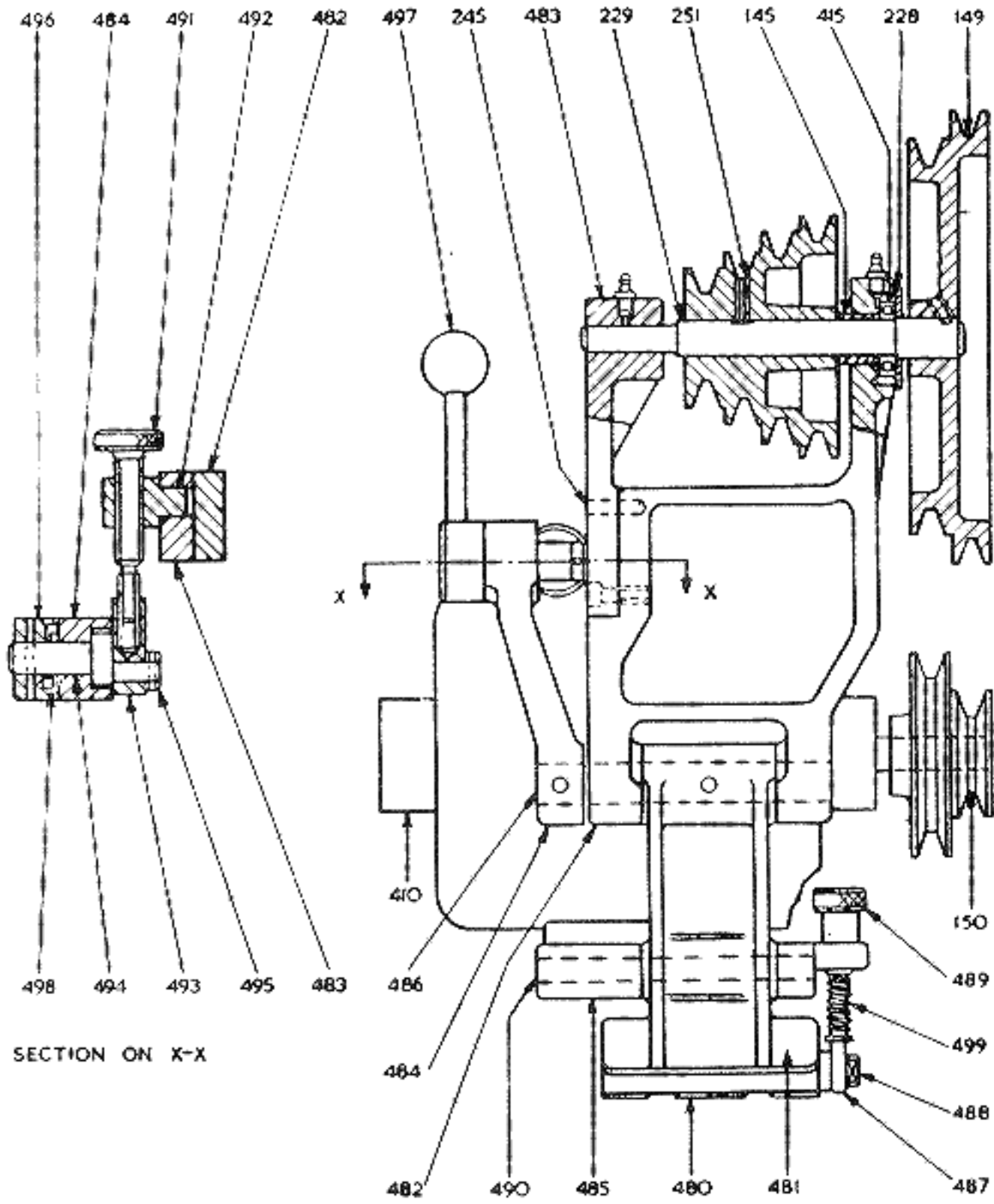

Diagram HA. Countershaft

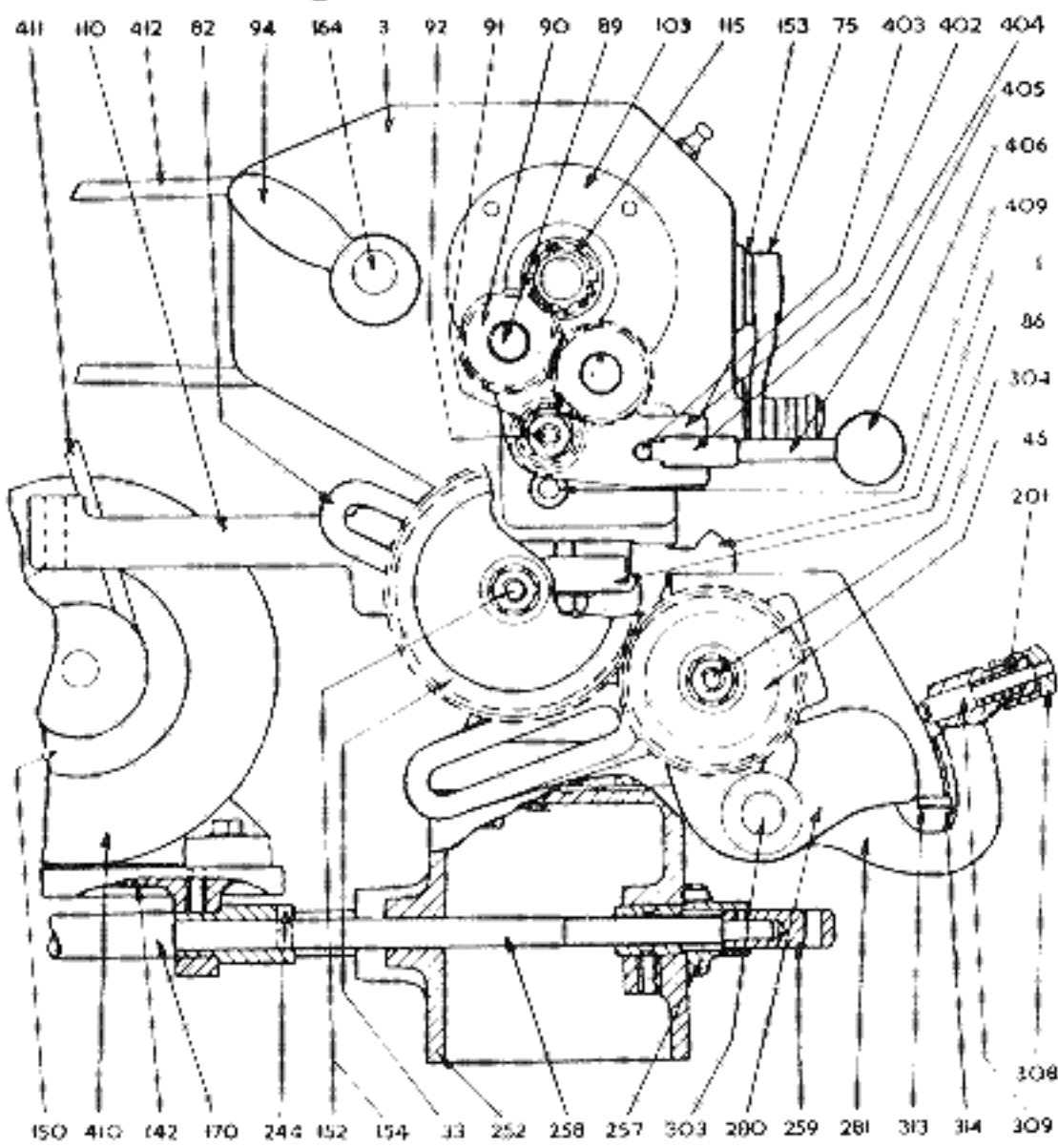

Diagram GA. Change Gears

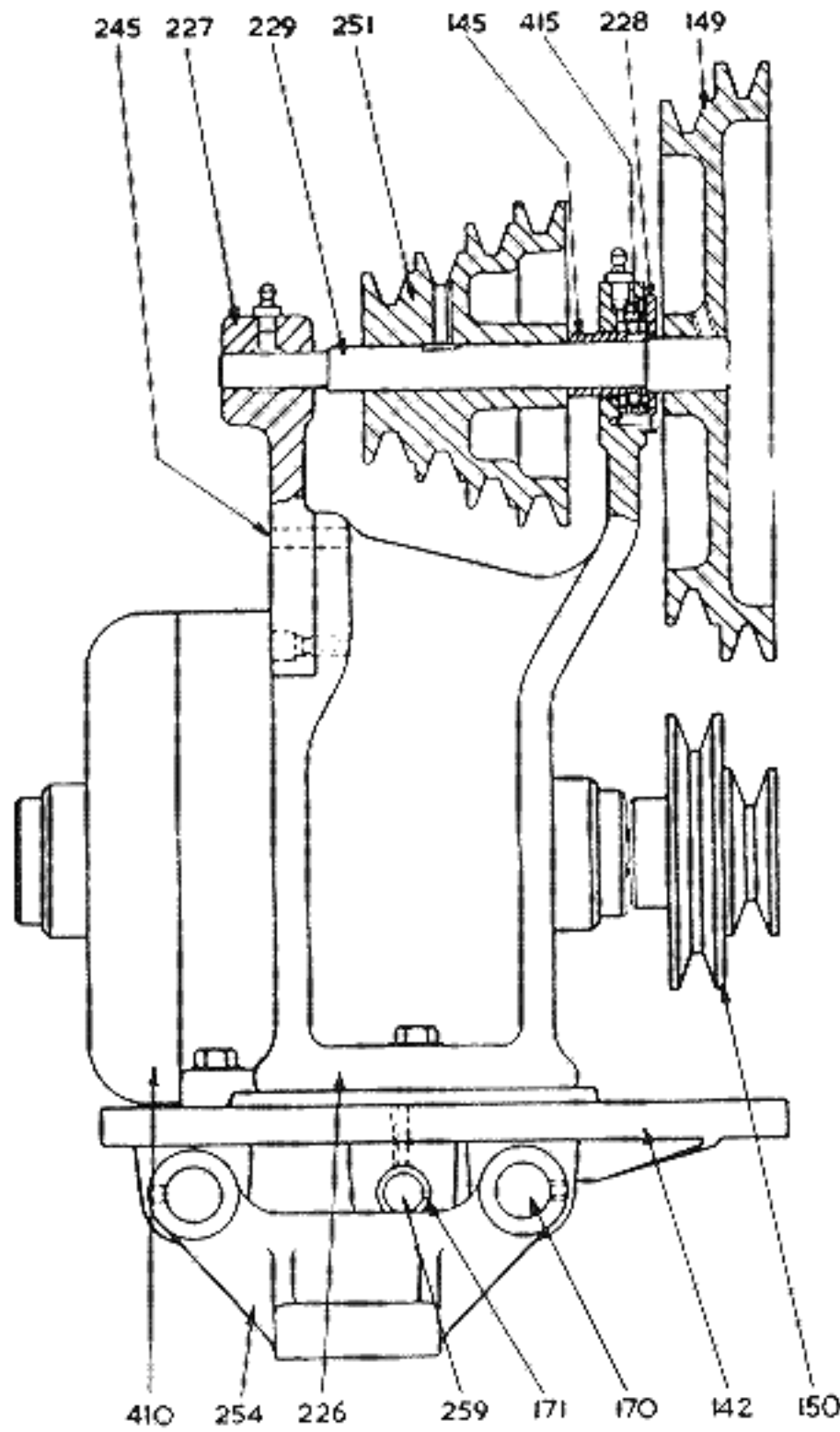

Diagram FA. Old Type Countershaft

NOTE

When ordering spares or replacement parts, please quote the serial number and model (to be found between front vee and flat at tailstock end of bed), the bed length and in the case of electrical equipment, the mains supply voltage, frequency, rating (amps) and whether single or three phase. It would assist if the line drawing diagram reference is given, and also the bore size of any pulleys required.

METHOD OF CHECKING PRE-LOADING OF SPINDLE

1. Move belt on pulley in headstock so that it does not interfere with the rotation of the spindle.
 2. Fasten catch plate to spindle of machine.
 3. Make a loop approx 1" dia. at both ends of a length of string approx. 4ft. long.
 4. Attach one loop to cut out of catch plate and wind string round periphery.
 5. Hook spring balance on loop at free end.
 6. With the spring balance held horizontally walk backwards holding the balance and note the reading in pounds whilst the spindle is rotating.
 7. Multiply this balance reading by the radius of the catch plate (usually $2\frac{9}{16}$ ") and this will then give loading of spindle in "pounds inches".
 8. The pre-loading of the spindle varies with the speed and nature of work. For speeds up to 1400 r.p.m., between 1 and 2 lb. in. is usually satisfactory. For speeds 1400 to 2000 r.p.m. or over, between 1 and $1\frac{1}{2}$ lb. in. Do not exceed 2 lb. in. (i.e. approx. 1 lb. balance reading).
- N.B. Overgreasing of spindle bearings will increase loading and should be avoided.
9. Any adjustment can be done by tightening or slackening the locknut at the end of the spindle. When slackening, it may be necessary to gently tap the locknut end of the spindle with a hide or rubber mallet to release the pre-load after slackening the locknut.

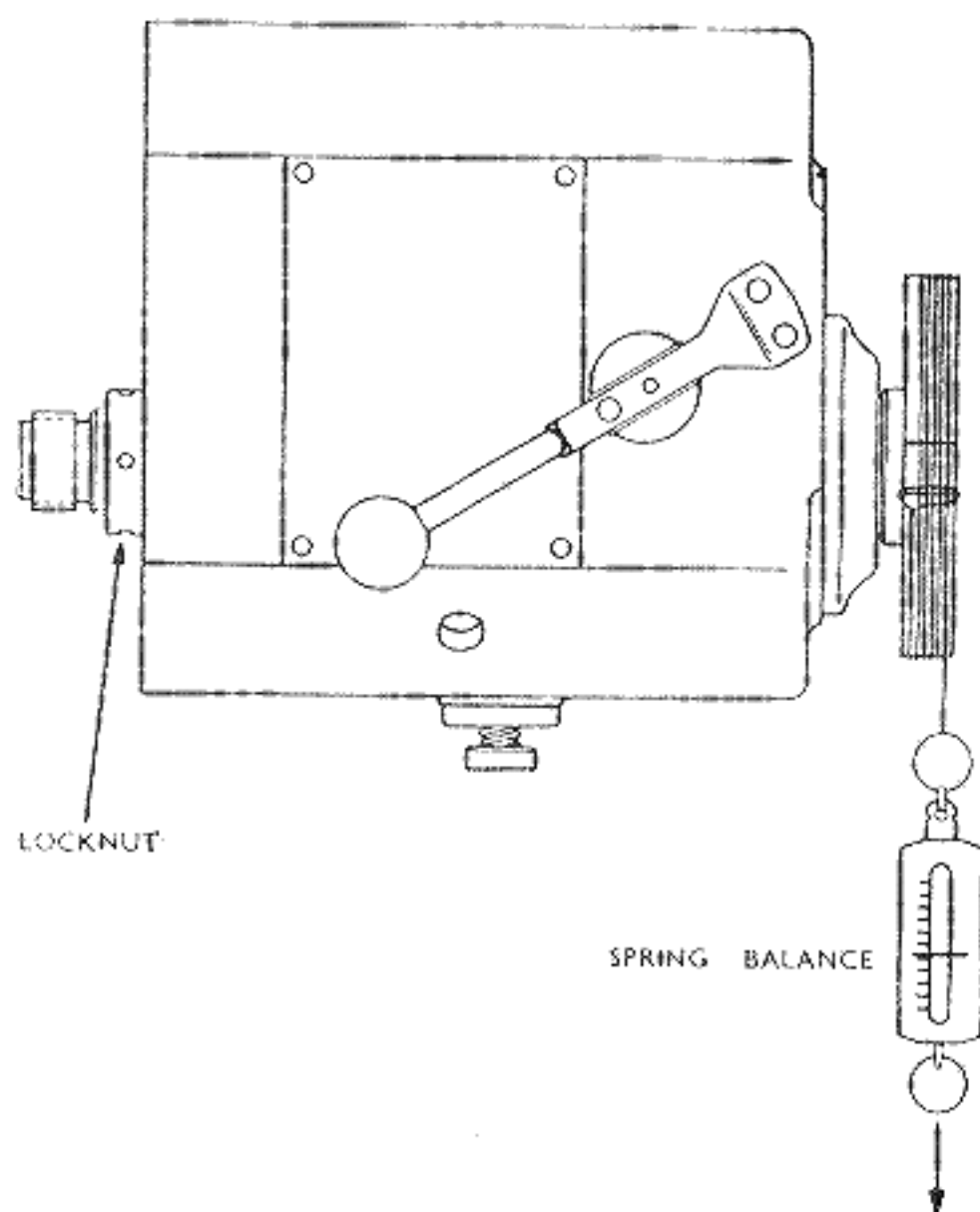

INSTRUCTIONS FOR DISMANTLING HEADSTOCK AND FITTING NEW BEARINGS

(see line drawings on page 11)

MARK II HEADSTOCK

1. Disconnect mains supply to machine.
2. Remove the rear sheet steel guard and top plate from the headstock.
3. Slacken off the screw securing back gear shaft (655), slide out shaft and remove the complete back gear sleeve (656 and 657).
4. Remove the screw and spring securing plunger (673) in lever body.
5. Slacken the screw securing pivot pin (672) in gear lever (654), remove pin and then the gear lever. If fitted, release switch locking screw (683) before removing lever.
6. Remove screwed pin (678) from gear shifter spindle (669) and lift out gear shifter boss (670).
7. Take out gear shifter bar (668) and shoes (667) etc.
8. Slacken the screws holding spindle locknut (666) in position and unscrew locknut.
9. Remove the front and rear covers (102 and 103), also spacing washer (166) from rear of spindle.
10. Using a soft hammer, gently tap spindle at rear until it is driven out through front of headstock so that cone of rear bearing can be removed.
11. Lift spindle sliding gear (663) out of spindle keyway and draw spindle out through front of headstock. It is advisable to have keyway at bottom to avoid burrs being thrown up on spindle. Make sure the sliding gear is free from drive pins (660) when withdrawing spindle.
12. Remove cone of front bearing from spindle.
13. Using a hardened pin (or pins) in the knock-out holes inside the headstock remove the bearing cups (outer races) from front and rear housings.
14. Place new bearing cups in their housings and gently press or tap home (see note i.).
15. Gently drive cone (inner race) of new front bearing on spindle.
16. Place spindle in headstock and replace the sliding gear (663) pulley (659) and spacing washer (664).
17. Gently drive cone (inner race) of new rear bearing on spindle and secure with spacing collar (166) and locknut (666) (see note i.).
18. Lightly smear bearings with grease before replacing front and rear covers (102 and 103).
19. Slacken locknut (666) and finger tighten to remove end play.
20. Rotate spindle by hand to expel all excess grease from rollers.
21. Tighten the locknut a fraction more to give slight pre-load to the spindle assembly and lock in position. Refer to method of checking pre-load.
22. To complete assembly, reverse dismantling procedure 1 to 7.

MARK I AND BENCH HEADSTOCK

1. Disconnect mains supply to machine.
2. Remove the sheet steel guard from headstock.
3. Slacken the grub screw which locates back gear shaft (164) with ball spring, also the grub screw in back gear handle (94) and push back gear shaft out through front of headstock. This will allow back gears (104) and (105) to be removed.

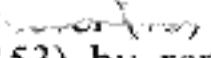
4. Remove gear shifter  by slackening grub screw. Withdraw eccentric (108) and headed bush (153) by removing countersunk screws from bush and pulling eccentric outwards.
5. Remove front and rear covers (102 and 103).
6. Slacken off and remove locknuts (119) and spacing washer (166) from rear of spindle.
7. Using a soft hammer, gently tap spindle at rear until it is driven out through front of headstock so that cone of rear bearing can be removed.
8. Lift spindle sliding gear (107) out of spindle keyway and draw spindle out through front of headstock. It is advisable to have keyway at bottom to avoid burrs being thrown up on spindle. Make sure that sliding gear is free from drive pins (196) when withdrawing spindle.
9. Remove cone of front bearing from spindle.
10. Using a hardened pin (or pins) in the knock-out holes inside the headstock, remove the bearing cups (outer races) from front and rear bearings.
11. Place new bearing cups in their housings and gently press or tap home (see note i.).
12. Gently drive cone (inner race) of new front bearing on spindle.
13. Place spindle in headstock and replace the sliding gear (107) pulley (250 on bench models, 602 on Mark I) and spacing washer (117).
14. Gently drive cone (inner race) of new rear bearing on spindle and secure with spacing collar (166) and locknut (119) (see note i.).
15. Lightly smear bearings with grease before replacing front and rear covers (102 and 103).
16. Slacken locknut (119) and finger tighten to remove end play.
17. Rotate spindle by hand to expel all excess grease from rollers.
18. Tighten the locknut a fraction more to give slight pre-load to the spindle assembly and lock in position with other locknut. Refer to method of checking pre-load.
19. To complete assembly, reverse dismantling procedure 1 to 4.

NOTES

- (i) It is essential that bearings and all parts are kept clean and free from dirt. Precision 3 bearings are identified by a copper dot which indicates the high point of any bearing run-out. The dots on the two bearing cups and cones should be aligned with each other to give the best results.
- (ii) When removing and fitting new bearings it will be found easier if the headstock is completely removed from the lathe bed. The two clamps beneath the headstock must first be released with a box wrench and any electrical wiring disconnected. The headstock can then be removed from the end of the lathe bed.

INSTRUCTIONS FOR REMOVAL OF CARRIAGE ASSEMBLY

1. Unclamp tailstock and slide off end of bed.
2. Wind carriage unit down to tailstock end of bed.
3. Remove gib strip from rear of saddle.
4. Remove the two securing screws fastening the leadscrew bracket (tailstock end) to the bed and slide bracket off end of leadscrew.
5. Supporting leadscrew by hand, slide carriage unit off end of bed.
6. Replace leadscrew bracket to support leadscrew.

If it is desired to remove the apron assembly only, proceed as 1 above, then remove the carriage locking screw from the saddle and the two screws securing the apron to the saddle and then as 4, 5 and 6 above.